

Multiscale inference for multivariate deconvolution

Konstantin Eckle, Nicolai Bissantz, Holger Dette

Ruhr-Universität Bochum

Fakultät für Mathematik

44780 Bochum, Germany

Abstract

In this paper we provide new methodology for inference of the geometric features of a multivariate density in deconvolution. Our approach is based on multiscale tests to detect significant directional derivatives of the unknown density at arbitrary points in arbitrary directions. The multiscale method is used to identify regions of monotonicity and to construct a general procedure for the detection of modes of the multivariate density. Moreover, as an important application a significance test for the presence of a local maximum at a pre-specified point is proposed. The performance of the new methods is investigated from a theoretical point of view and the finite sample properties are illustrated by means of a small simulation study.

Keywords and Phrases: deconvolution, modes, multivariate density, multiple tests, Gaussian approximation

AMS Subject Classification: 62G07, 62G10, 62G20

1 Introduction

In many applications such as in biological, medical imaging or signal detection only indirect observations are available for statistical inference, and these problems are called inverse problems in the (statistical) literature. In the case of medical imaging, a well-known example is Positron Emission Tomography. Here, the connection between the 'true' image and the observations involves the Radon transform [see, for example, Cavalier (2000)]. Other typical examples are the reconstruction of biological or astronomical images, where the connection between the true image and the observable image is - at least in a first approximation - given by convolution-type operators [see, for example, Adorf (1995) or Bertero et al. (2009)]. Whereas in these models the data is in general described in a regression framework, similar (de-)convolution problems arise

in density estimation from indirect observations [see Diggle and Hall (1993) for an early reference]. The corresponding (multivariate) statistical model for density deconvolution is defined by

$$Y_i = Z_i + \varepsilon_i, \quad i = 1, \dots, n, \quad (1.1)$$

where $(Z_1, \varepsilon_1), \dots, (Z_n, \varepsilon_n) \in \mathbb{R}^d \times \mathbb{R}^d$ are independent identically distributed random variables and the noise terms $\varepsilon_1, \dots, \varepsilon_n$ are also independent of the random variables Z_1, \dots, Z_n . We assume that the density f_ε of the errors ε_i is known and are interested in properties of the density f of the random variables Z_i based on the sample $\{Y_1, \dots, Y_n\}$. In terms of densities, model (1.1) can be rewritten as

$$g = f * f_\varepsilon,$$

where g denotes the density of Y_1 . Density estimators can be constructed and investigated similarly to the regression case (see the references in the next paragraph), and in this paper we are interested in describing qualitative features of the density f using the sample $\{Y_1, \dots, Y_n\}$. In particular we will develop a method for simultaneous detection of regions of monotonicity of the density f at a controlled level and construct a procedure for the detection of the modes of f . To our best knowledge multivariate problems of this type have not been investigated so far in the literature.

On the other hand there exists a wide range of literature concerning statistical inference in the univariate deconvolution model. A Fourier-based estimate of the density f using a damping factor for large frequencies was introduced in Diggle and Hall (1993), whereas Pensky and Vidakovic (1999) estimate f with a wavelet-based deconvolution density estimator [see also van Es et al. (1998) for a nonparametric estimator for the corresponding distribution function or Butucea and Matias (2005) for a plug-in estimator of f based on estimation of a scale parameter for the noise level]. Bissantz et al. (2007) develop confidence bands for deconvolution kernel density estimators, while minimax rates for this estimation problem can be found in Carroll and Hall (1988) and Fan (1991). Romano (1988) and Grund and Hall (1995) point out that the detection of regions of monotonicity and of the modes of a density is a more complex problem and Fan (1991) shows that the minimax rate for estimating the derivative over a Hölder- β -class ($\beta \geq 2$) in the univariate setting $d = 1$ is given by $n^{-(\beta-1)/(2\beta+2r+1)}$, where $r > 0$ denotes the order of polynomial decay of the Fourier transform of the error density f_ε . Balabdaoui et al. (2010) develop a test for the number of modes of a univariate density and Meister (2009) proposes a local test for monotonicity for a fixed interval. More recently Schmidt-Hieber et al. (2013) discuss multiscale tests for qualitative features of a univariate density which provide uniform confidence statements about shape constraints such as local monotonicity properties. Little research has been done regarding multivariate deconvolution problems. Recent references for density estimation are e.g. Comte and Lacour (2013) using kernel density estimators and Sarkar et al. (2015) for a Bayesian approach in the case of an unknown error distribution with

replicated proxies available. Hypothesis testing in deconvolution is investigated in Holzmann et al. (2007) and Bissantz and Holzmann (2008).

In the present paper we will develop a multiscale method for simultaneous identification of regions of monotonicity of the multivariate density f in the deconvolution model (1.1). Our approach is based on simultaneous local tests of the directional derivatives of the density f for a significant deviation from zero for “various” directions and locations. In Section 2 we present a Fourier based method for the construction of local tests, which will be used for the inference about the monotonicity properties of the density f . Roughly speaking, we propose a multiscale test investigating the sign of the derivatives of the density f in different locations and directions and on different scales. Section 3 is devoted to asymptotic properties, which can be used to obtain a multiscale test for simultaneous confidence statements about the density. Moreover, we also propose a method for the detection and localization of the modes. The finite sample properties of the method are discussed in Section 4 and all proofs are deferred to Sections 5 and 6, while Section 7 contains two technical results.

2 Multiscale inference in multivariate deconvolution

Let ∂_s denote the directional derivative in the direction of $s \in S^{d-1} = \{s \in \mathbb{R}^d \mid \|s\| = 1\}$ and $\phi : \mathbb{R}^d \rightarrow \mathbb{R}_{\geq 0}$ be a sufficiently smooth kernel (i.e. $\|\phi\|_{L^1(\mathbb{R}^d)} = 1$) with compact support in $[-1, 1]^d$. Define

$$\phi_{t,h}(\cdot) = h^{-d} \phi\left(\frac{\cdot - t}{h}\right) \quad \text{for } t \in [0, 1]^d, h > 0.$$

For the description of the local monotonicity properties of the function f we introduce the integral

$$- \int_{\mathbb{R}^d} \partial_s f(x) \phi_{t,h}(x) dx. \quad (2.1)$$

If this expression is, say, negative, we can conclude that the derivative of f in direction s has to be strictly larger than zero on a subset of positive Lebesgue measure of the cube $[t_1 - h, t_1 + h] \times \dots \times [t_d - h, t_d + h]$.

Statistical inference regarding the monotonicity properties of f can then be performed by testing simultaneously several hypotheses of the form

$$H_{0,incr}^{s^j, t^j, h_j} : - \int_{\mathbb{R}^d} \partial_{s^j} f(x) \phi_{t^j, h_j}(x) dx \geq 0 \quad \text{versus} \quad H_{1,incr}^{s^j, t^j, h_j} : - \int_{\mathbb{R}^d} \partial_{s^j} f(x) \phi_{t^j, h_j}(x) dx < 0 \quad (2.2)$$

and

$$H_{0,decr}^{s^j, t^j, h_j} : - \int_{\mathbb{R}^d} \partial_{s^j} f(x) \phi_{t^j, h_j}(x) dx \leq 0 \quad \text{versus} \quad H_{1,decr}^{s^j, t^j, h_j} : - \int_{\mathbb{R}^d} \partial_{s^j} f(x) \phi_{t^j, h_j}(x) dx > 0, \quad (2.3)$$

where $(s^1, t^1, h_1), \dots, (s^p, t^p, h_p)$ are given triples of directions, locations and scaling factors.

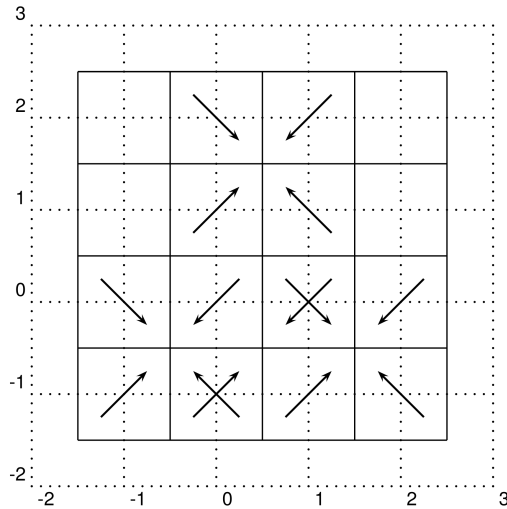

Figure 1: *Example of a global map for monotonicity of a bivariate density.*

This method allows for a global understanding of the shape of the density f . A particular feature of the proposed method consists in the fact that by conducting formal statistical tests the multiple level can be controlled (see Theorem 3.2).

For example, simultaneous tests for hypotheses of the form (2.2) and (2.3) can be used to obtain a graphical representation of the local monotonicity behavior of the density as displayed in Figure 1 for a bivariate density. The displayed map is based on tests for the hypotheses (2.2) for a fixed scale h_0 and different locations and directions $(s^1, t^1), \dots, (s^p, t^p)$ (here taken as the vertices of an equidistant grid and four equidistant directions on S^1). Note that we are investigating here a symmetric set of triples, that is, for every location t^j both the triple (s^j, t^j, h_0) and $(-s^j, t^j, h_0)$ are considered. Thus, as $H_{0,incr}^{s^j, t^j, h_0} = H_{0,decr}^{-s^j, t^j, h_0}$, it is sufficient to investigate only hypotheses of the form (2.2) in this setting. The figure shows the results of the tests for the different hypotheses in (2.2). An arrow in a direction s^j at a location t^j represents a rejection of the corresponding hypothesis $H_{0,incr}^{s^j, t^j, h_0}$ and provides therefore an indication of a positive directional derivative of f in direction s^j at the location t^j . For a detailed description of the settings used to provide Figure 1 and an analysis of the results we refer to Section 4.2. If one is interested in specific shape constraints of the density, say in a test for a mode (local maximum) at a given point x^0 , inference can be conducted investigating the hypotheses

$$H_{0,decr}^{s^j, t^j, h_0} \quad \text{versus} \quad H_{1,decr}^{s^j, t^j, h_0} \quad (2.4)$$

for different pairs $(t^1, s^1), \dots, (t^p, s^p)$, where t^1, \dots, t^p are points in a neighborhood of x^0 on the lines $\{x^0 + \lambda s^j | \lambda > 0\}$ ($j = 1, \dots, p$), respectively (of course, on could additionally use different scales here).

Throughout this paper we will assume that all partial derivatives $\partial_s f$ of the density f are uniformly bounded, such that the estimated quantity (2.1) is bounded by a constant which does not depend on the triple (s, t, h) . Using integration by parts, Plancherel's identity and the convolution theorem, we get

$$\begin{aligned}
-\int_{\mathbb{R}^d} \partial_s f(x) \phi_{t,h}(x) dx &= \int_{\mathbb{R}^d} f(x) \partial_s \phi_{t,h}(x) dx \\
&= \frac{1}{(2\pi)^d} \int_{\mathbb{R}^d} \mathcal{F}(f)(y) \overline{\mathcal{F}(\partial_s \phi_{t,h})(y)} dy \\
&= \frac{1}{(2\pi)^d} \int_{\mathbb{R}^d} \mathcal{F}(g)(y) \overline{\left(\frac{\mathcal{F}(\partial_s \phi_{t,h})}{\mathcal{F}(f_\varepsilon)} \right)}(y) dy \\
&= \int_{\mathbb{R}^d} g(x) \mathcal{F}^{-1} \left(\frac{\mathcal{F}(\partial_s \phi_{t,h})}{\mathcal{F}(f_\varepsilon)} \right) (x) dx.
\end{aligned} \tag{2.5}$$

Here,

$$\begin{aligned}
\mathcal{F}(f)(y) &= \int_{\mathbb{R}^d} e^{-iy \cdot x} f(x) dx, \\
\mathcal{F}^{-1}(f)(x) &= \frac{1}{(2\pi)^d} \int_{\mathbb{R}^d} e^{ix \cdot y} f(y) dy \quad (x, y \in \mathbb{R}^d)
\end{aligned}$$

denote the Fourier transform and its inverse, respectively, \bar{z} is the complex conjugate of $z \in \mathbb{C}$ and $x \cdot y$ stands for the standard inner product of $x, y \in \mathbb{R}^d$.

For the construction of tests for the hypotheses in (2.2) and (2.3) we define the statistic

$$T_{s,t,h}^n = \frac{1}{n} \sum_{i=1}^n F_{s,t,h}(Y_i), \tag{2.6}$$

where

$$F_{s,t,h}(Y_i) = \mathcal{F}^{-1} \left(\frac{\mathcal{F}(\partial_s \phi_{t,h})}{\mathcal{F}(f_\varepsilon)} \right) (Y_i). \tag{2.7}$$

Because (by (2.5))

$$\mathbb{E}(T_{s,t,h}^n) = - \int_{\mathbb{R}^d} \partial_s f(x) \phi_{t,h}(x) dx,$$

it follows that $T_{s,t,h}^n$ is a reasonable estimate of the quantity defined in (2.1), and hence the statistics $T_{s,t,h}^n$ define the main tool to study qualitative features of the density f . Inference on local monotonicity of the density f will then be based on tests rejecting the hypotheses $H_{0,incr}^{s,t,h}$ for small values of the corresponding statistic $T_{s,t,h}^n$ and rejecting $H_{0,decr}^{s,t,h}$ for large values of $T_{s,t,h}^n$ for several directions $s \in S^{d-1}$, locations $t \in [0, 1]^d$ and scales $h > 0$. The multiple level of these tests can be controlled by investigating the (asymptotic) maximum of appropriately normalized statistics $T_{s,t,h}^n$ calculated over a certain set of locations, directions and scales.

3 Asymptotic properties

In this section we investigate the asymptotic properties of a statistic which can be used to control the multiple level of the tests introduced in Section 2. To be precise, we consider the finite subset

$$\mathcal{T}_n := \{(s^j, t^j, h_j) \mid j = 1, \dots, p\} \subseteq S^{d-1} \times [0, 1]^d \times [h_{\min}, h_{\max}]$$

of cardinality $p \leq n^K$ for the calculation of the maximum of appropriately standardized statistics $T_{s,t,h}^n$, where $K > 1$ and for some $\varepsilon > 0$

$$h_{\min} \gtrsim n^{-1/d+\varepsilon} \quad \text{and} \quad h_{\max} = o((\log(n) \log \log(n))^{-1}). \quad (3.1)$$

Throughout this paper we will make frequent use of multi-index notation, where $\boldsymbol{\alpha} = (\alpha_1, \dots, \alpha_d) \in \mathbb{N}_0^d$ denotes a multi-index (written in bold), $|\boldsymbol{\alpha}| = \alpha_1 + \dots + \alpha_d$ its ‘‘length’’, and for a sufficiently smooth function $f : \mathbb{R}^d \rightarrow \mathbb{R}$ and a multi-index $\boldsymbol{\alpha}$ we denote by

$$\partial^{\boldsymbol{\alpha}} f(x) = \frac{\partial^{|\boldsymbol{\alpha}|}}{\partial x_1^{\alpha_1} \cdot \dots \cdot \partial x_d^{\alpha_d}} f(x)$$

its partial derivative.

Recall the definition of $F_{s,t,h}$ in (2.7), to simplify the notation define for a point $(s^j, t^j, h_j) \in \mathcal{T}_n$

$$F_j = F_{s^j, t^j, h_j} \quad (3.2)$$

and consider the random variables

$$\tilde{X}_j^{(1)} = \frac{\sqrt{\log(eh_j^{-d})}}{\log \log(e^e h_j^{-d})} \left(\frac{h_j^{d/2+r+1}}{\sqrt{n \hat{g}_n(t_j)} V_j} \left| \sum_{i=1}^n F_j(Y_i) - n \mathbb{E}(F_j(Y_1)) \right| - \sqrt{2 \log(h_j^{-d})} \right), \quad (3.3)$$

where \hat{g}_n is a density estimator of g satisfying

$$\|g - \hat{g}_n\|_{\infty} = o(\log(n)^{-1}) \quad \text{almost surely} \quad (3.4)$$

(for example a kernel density estimator as considered in Giné and Guillou (2002)) and

$$V_j = h_j^{d/2+r+1} \|F_{s^j, t^j, h_j}\|_{L^2(\mathbb{R}^d)}. \quad (3.5)$$

The quantity V_j is well-defined under the assumptions presented below (see Lemma 5.2 for details).

Note that the boundary of the hypotheses $H_{0,incr}^{s^j, t^j, h_j}$ and $H_{0,decr}^{s^j, t^j, h_j}$ in (2.2) and (2.3) is defined by $\int_{\mathbb{R}^d} \partial_{s^j} f(x) \phi_{t^j, h_j}(x) dx = 0$ and in this case we have

$$\frac{1}{\sqrt{n}} \tilde{X}_j^{(1)} = \frac{\sqrt{\log(eh_j^{-d})}}{\log \log(e^e h_j^{-d})} \left(\frac{h_j^{d/2+r+1}}{\sqrt{\hat{g}_n(t_j)} V_j} |T_{s^j, t^j, h_j}^n| - \frac{\sqrt{2 \log(h_j^{-d})}}{\sqrt{n}} \right).$$

Consequently, we will investigate the asymptotic properties of $\max_{1 \leq j \leq p} \tilde{X}_j^{(1)}$ in the following discussion. For this purpose we make the following assumptions.

Assumption 1. Assume that the density g is Lipschitz continuous and locally bounded from below, i.e.

$$g(x) \geq c > 0 \text{ for all } x \in [0, 1]^d.$$

Assumption 2. We assume a polynomial decay of the Fourier transform of the error density f_ε , i.e. that there exist constants $r > 0$ for $d \geq 2$ resp. $r > \frac{1}{2}$ for $d = 1$ and $0 < C_u < C_o$ such that

$$C_u(1 + \|y\|^2)^{-r/2} \leq |\mathcal{F}(f_\varepsilon)(y)| \leq C_o(1 + \|y\|^2)^{-r/2}.$$

Furthermore, let

$$\sum_{j=1}^{\lceil (d+1)/2 \rceil} (1 + \|y\|^2)^{j/2} \left| \frac{\partial^j}{\partial y_l^j} \mathcal{F}(f_\varepsilon)(y) \right| \leq C_o(1 + \|y\|^2)^{-r/2}$$

for all $l = 1, \dots, d$.

Note that as a direct consequence of Assumption 1 g is bounded from above and that there exists a constant $\delta > 0$ such that $g(x) \geq \frac{\varepsilon}{2} > 0$ for all $x \in [-\delta, 1 + \delta]^d$. Assumption 2 can be seen as a multivariate generalization of the classical assumptions on the decay of the Fourier transform of the error density in the ordinary smooth case (see e.g. Schmidt-Hieber et al. (2013), Assumption 2). We also note that this assumption defines a mildly ill-posed situation (see Bissantz and Holzmann (2008)). The next assumptions refer to the kernel ϕ and are required for some technical arguments.

Assumption 3. Let $\|\partial_s \phi\|_{L^2(\mathbb{R}^d)} \neq 0$ for all $s \in S^{d-1}$ and assume that $\partial^\beta \phi$ exists in $[-1, 1]^d$ and is continuous for all $|\beta| \leq \lceil r + 2 \rceil$, where r is the constant from Assumption 2. We assume further that for some $\delta > 0$ the inequality

$$\int_{\mathbb{R}^d} (1 + \|y\|^2)^{r+(d+\delta)/2} \left| \frac{\partial^m}{\partial y_l^m} \mathcal{F}(\partial_{e^k} \phi)(y) \right|^2 dy < \infty$$

holds for all $k, l = 1, \dots, d$ and $m = 0, \dots, \lceil (d+1)/2 \rceil$, where e^k , $k = 1, \dots, d$, denotes the k th unit vector of \mathbb{R}^d .

As

$$\left| \frac{\partial^m}{\partial y_l^m} \mathcal{F}(\partial_s \phi)(y) \right|^2 = \left| \sum_{k=1}^d s_k \frac{\partial^m}{\partial y_l^m} \mathcal{F}(\partial_{e^k} \phi)(y) \right|^2 \leq C \sum_{k=1}^d \left| \frac{\partial^m}{\partial y_l^m} \mathcal{F}(\partial_{e^k} \phi)(y) \right|^2$$

for all $s \in S^{d-1}$ and some constant $C > 0$ that only depends on d , Assumption 3 yields a uniform upper bound for the integral

$$\int_{\mathbb{R}^d} (1 + \|y\|^2)^{r+(d+\delta)/2} \left| \frac{\partial^m}{\partial y_l^m} \mathcal{F}(\partial_s \phi)(y) \right|^2 dy$$

for all $s \in S^{d-1}$.

Recall the definition of $\tilde{X}_j^{(1)}$ in (3.3) and define the vector $\tilde{X}^{(1)} = (\tilde{X}_1^{(1)}, \dots, \tilde{X}_p^{(1)})^\top$. Our first main result provides a uniform approximation of the probabilities $\mathbb{P}(\tilde{X}^{(1)} \in A)$ by the probabilities $\mathbb{P}(\tilde{X} \in A)$ for every half-open hyperrectangle A , where the components of the vector $\tilde{X} = (\tilde{X}_1, \dots, \tilde{X}_p)^\top$ are defined by

$$\tilde{X}_j = \frac{\sqrt{\log(eh_j^{-d})}}{\log \log(e^e h_j^{-d})} \left(h_j^{d/2+r+1} \frac{|\int_{\mathbb{R}^d} F_j(x) dB_x|}{V_j} - \sqrt{2 \log(h_j^{-d})} \right) \quad (3.6)$$

($j = 1, \dots, p$), and $(B_x)_{x \in \mathbb{R}^d}$ is a standard d -variate Brownian motion.

Theorem 3.1. *Let \mathcal{A} denote the set $\mathcal{A} := \{(-\infty, a_1] \times \dots \times (-\infty, a_p] \mid a_1, \dots, a_p \in \mathbb{R}\}$. Then,*

$$\sup_{A \in \mathcal{A}} |\mathbb{P}(\tilde{X}^{(1)} \in A) - \mathbb{P}(\tilde{X} \in A)| = o(1) \quad \text{for } n \rightarrow \infty. \quad (3.7)$$

Furthermore, the random variable $\max_{1 \leq j \leq p} \tilde{X}_j$ is almost surely bounded uniformly with respect to n .

Theorem 3.1 will be used to control the multiple level of statistical tests for the hypotheses of the form (2.2) and (2.3). To this end, let $\alpha \in (0, 1)$ and denote by $\kappa_n(\alpha)$ the smallest number such that

$$\mathbb{P}\left(\max_{1 \leq j \leq p} \tilde{X}_j \leq \kappa_n(\alpha)\right) \geq 1 - \alpha. \quad (3.8)$$

By Theorem 3.1, $\kappa_n(\alpha)$ is bounded uniformly with respect to n and α . The j th hypothesis in (2.2) is rejected, whenever

$$n^{-1} \sum_{i=1}^n F_j(Y_i) < -\kappa_n^j(\alpha), \quad (3.9)$$

where

$$\kappa_n^j(\alpha) = \frac{\sqrt{\hat{g}_n(t_j)} V_j}{\sqrt{n}} h_j^{-d/2-r-1} \left(\frac{\log \log(e^e h_j^{-d})}{\sqrt{\log(eh_j^{-d})}} \kappa_n(\alpha) + \sqrt{2 \log(h_j^{-d})} \right). \quad (3.10)$$

Similarly, the j th hypothesis in (2.3) is rejected, whenever

$$n^{-1} \sum_{i=1}^n F_j(Y_i) > \kappa_n^j(\alpha). \quad (3.11)$$

Theorem 3.2. *Assume that the tests (3.9) and (3.11) for the hypotheses (2.2) and (2.3) are performed simultaneously for $j = 1, \dots, p$. The probability of at least one false rejection of any of the tests is asymptotically at most α , that is*

$$\mathbb{P}\left(\exists j \in \{1, \dots, p\} : n^{-1} \left| \sum_{i=1}^n F_j(Y_i) \right| > \kappa_n^j(\alpha)\right) \leq \alpha + o(1)$$

for $n \rightarrow \infty$.

Next we introduce a method for the detection and localization of the modes of the density. The main idea is to conduct the local tests for modality proposed in (2.4) for a set of candidate modes which does not assume any prior knowledge about the density. To be precise, we assume the following condition on the set \mathcal{T}_n : for any fixed h and s the set $\{t : (s, t, h) \in \mathcal{T}_n\}$ is an equidistant grid in $[0, 1]^d$ with grid width h . Furthermore, for any fixed t and h the set $\{s : (s, t, h) \in \mathcal{T}_n\}$ is a grid in S^{d-1} with grid width converging to zero with increasing sample size.

This grid is now used as follows to check if a point $x^0 \in (0, 1)^d$ is a mode of f . Let $\mathcal{T}_n^{x^0} \subset \mathcal{T}_n$ be the set of all triples $(s, t, h) \in \mathcal{T}_n$ such that $ch \geq \|x^0 - t\| \geq 2\sqrt{d}h$ for some $c > 2\sqrt{d}$ sufficiently large and $\text{angle}(x^0 - t, s) \rightarrow 0$ for $n \rightarrow \infty$. By the condition on \mathcal{T}_n defined above, the set $\mathcal{T}_n^{x^0}$ is nonempty for sufficiently large n . We now use the local tests (3.11) for the hypotheses (2.4) and decide for a mode at the point x^0 if the null hypotheses in (2.4) are rejected for all triples in $\mathcal{T}_n^{x^0}$. Note that by choosing the test locations as the vertices of an equidistant grid no prior knowledge about the location of x^0 has to be assumed. Theorem 3.3 below states that the procedure detects all modes of the density with asymptotic probability one as $n \rightarrow \infty$.

Theorem 3.3. *Let $x^0 \in (0, 1)^d$ denote an arbitrary mode of the density f and assume that there exist functions $g_{x^0} : \mathbb{R}^d \rightarrow \mathbb{R}$, $\tilde{f}_{x^0} : \mathbb{R} \rightarrow \mathbb{R}$ such that the density f has a representation of the form*

$$f(x) \equiv (1 + g_{x^0}(x))\tilde{f}_{x^0}(\|x - x^0\|) \quad (3.12)$$

(in a neighborhood of x^0), g_{x^0} is differentiable in a neighborhood of the point x^0 such that $g_{x^0}(x) = o(1)$ and $\langle \nabla g_{x^0}(x), e \rangle = o(\|x - x^0\|)$ if $x \rightarrow x^0$ for all $e \in \mathbb{R}^d$ with $\|e\| = 1$. In addition, let \tilde{f}_{x^0} be differentiable in a neighborhood of the point 0 with $\tilde{f}'_{x^0}(h) \leq -ch(1 + o(1))$ for $h \rightarrow 0$.

If the set

$$\{(s, t, h) \in \mathcal{T}_n : h \geq C \log(n)^{1/(d+2r+4)} n^{-1/(d+2r+4)}\}$$

for some $C > 0$ sufficiently large is nonempty, then the procedure described in the previous paragraph detects the mode x^0 with asymptotic probability one as $n \rightarrow \infty$.

The method to detect the modes of the density proposed in Theorem 3.3 proceeds in two steps: the verification of the presence of a mode with asymptotic probability one in the asymptotic regime presented above and its localization at the rate $n^{-1/(d+2r+4)}$ (up to some logarithmic factor) given by the grid width.

4 Finite sample properties

In this section we illustrate the finite sample properties of the proposed multiscale inference. The performance of the test for modality at a given point x^0 (see the hypotheses in (2.4)) and

the dependence of its power on the bandwidth and the error variance is investigated. We also illustrate how simultaneous tests for hypotheses of the form (2.2) and (2.3) can be used to obtain a graphical representation of the local monotonicity properties of the density.

We consider two-dimensional densities, i.e. $d = 2$. The density f_ε of the errors in model (1.1) is given by a symmetric bivariate Laplacian with scale parameter $\sigma > 0$ which is defined through its characteristic function

$$\mathcal{F}(f_\varepsilon)(y_1, y_2) = \frac{1}{1 + \frac{1}{2}\sigma^2(y_1^2 + y_2^2)} \quad (4.1)$$

for $(y_1, y_2) \in \mathbb{R}^2$ (cf. Kotz et al. (2001), Chapter 5). This means that $r = 2$ and straightforward calculations show that

$$F_{s,t,h}(x_1, x_2) = \mathcal{F}^{-1}\left(\frac{\mathcal{F}(\partial_s \phi_{t,h})}{\mathcal{F}(f_\varepsilon)}\right)(x_1, x_2) = \left(\partial_s - \frac{\sigma^2}{2}(\partial_{e_1}^2 \partial_s + \partial_{e_2}^2 \partial_s)\right)\phi_{t,h}(x_1, x_2) \quad (4.2)$$

for $(x_1, x_2) \in \mathbb{R}^2$. The test function is chosen as

$$\phi(x_1, x_2) = c_2(1 - x_1^4)(1 - x_2^4)\mathbb{1}\{|x_1| \leq 1, |x_2| \leq 1\},$$

where c_2 defines the normalization constant, that is

$$c_2 = \|(1 - x_1^4)(1 - x_2^4)\mathbb{1}\{|x_1| \leq 1, |x_2| \leq 1\}\|_{L^1(\mathbb{R}^d)}^{-1}$$

(note that ϕ is smooth within its support). Moreover, the integration by parts formula gives

$$-\int_{\mathbb{R}^2} \partial_s f(x)\phi_{t,h}(x) dx = \int_{\mathbb{R}^2} f(x)\partial_s \phi_{t,h}(x) dx$$

as ϕ vanishes on the boundary of its support. Finally, by the representation (4.2) we find that the deconvolution kernel possesses all properties that are used for the proof of Theorem 3.1 and therefore Theorem 3.1 is also satisfied for the function ϕ .

Throughout this section the nominal level is fixed as $\alpha = 0.05$.

4.1 A local test for modality

In this section we investigate the performance of a local test for the existence of a mode (more precisely a local maximum) at a given location x^0 which is defined by testing several hypotheses of the form (2.4) simultaneously. Moreover, the influence of the choice of the different parameters on the power of the test is also investigated. To be precise, we conduct four tests for the hypotheses (2.4) with a fixed bandwidth $h = h_0$. The postulated mode is given by the point $x^0 = (0, 0)^\top$ and the four directions and locations are chosen as $s^1 = t^1 = (1, 0)^\top$,

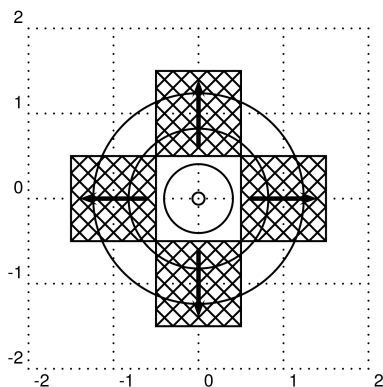

Figure 2: *Illustration of the four local tests for monotonicity used to define the test (4.3) for $h_0 = 0.5$. The crosshatched squares display the support of the functions F_{s^j, t^j, h_0} , $j = 1, \dots, 4$, and the arrows the directional vectors s^j , $j = 1, \dots, 4$.*

$s^2 = t^2 = (0, 1)^\top$, $s^3 = t^3 = (-1, 0)^\top$ and $s^4 = t^4 = (0, -1)^\top$. We conclude that f has a local maximum at the point $x^0 = (0, 0)^\top$, whenever all hypotheses

$$H_{0,decr}^{s^j, t^j, h_0}, \quad j = 1, \dots, 4,$$

are rejected, that is

$$T_{s^j, t^j, h_0}^n > \kappa_n^j(\alpha) \quad \text{for all } j = 1, \dots, 4, \quad (4.3)$$

where $\kappa_n^j(\alpha)$ is defined by (3.10). An illustration of the considered situation is provided in Figure 2. The quantiles $\kappa_n(0.05)$ defined in (3.8) are derived by 1000 simulation runs based on normal distributed random vectors. In Table 1 we display the normalized quantiles $\sqrt{n}\kappa_n^1(0.05)$ for the sample sizes $n = 500, 1000, 4000$ observations and $h_0 = 0.5$. Here, the value of the parameter of the Laplacian error density has been chosen as $\sigma = 0.075$.

n	$\sqrt{n}\kappa_n^1(0.05)$
500	0.039
1000	0.044
4000	0.041

Table 1: *Simulated quantiles $\sqrt{n}\kappa_n^1(0.05)$ of the test (4.3). The density f_ε is defined in (4.1).*

The approximation of the level of the test for a mode at the point x^0 defined by (4.3) is investigated using a uniform distribution on the square $[-2.5, 2.5]^2$ for the density f . For power considerations we sample the Z_i in model (1.1) from a standard normal distribution. The results are displayed in the left part of Table 2. By its construction, the multiscale method is

rather conservative but nevertheless it is able to detect the mode with increasing sample size. In order to obtain a better approximation of the nominal level we propose a calibrated version of the test, where the quantiles are chosen such that the test keeps its nominal level $\alpha = 0.05$. Note that this calibration does not require any knowledge about the unknown density f . The simulated rejection probabilities are presented in the right part of Table 2 for the parameters $h_0 = 0.5$ and $\sigma = 0.075$. We find that the calibrated test performs very well.

n	level	power	level (cal.)	power (cal.)
500	0.3	39.4	4.2	74.7
1000	0.1	71.1	4.0	93.3
4000	0.4	99.9	3.1	100

Table 2: *Simulated level and power of the test (4.3) for a mode at the point $x^0 = (0, 0)^\top$ of a 2-dimensional density. The random variables Z_i in model (1.1) are standard normal distributed. Second and third column: test defined by (4.3); fourth and fifth column: test defined by (4.3), where the quantiles $\kappa_n^j(\alpha)$ are replaced by calibrated quantiles.*

Next we fix the number of observations, that is $n = 1000$, the value of the parameter $\sigma = 0.075$ and vary the bandwidth h_0 to investigate its influence on the power of the test (4.3). Recall that by the proposed choice of a Laplacian error density, the deconvolution kernel has compact support in $[-1, 1]^2$. Hence, by dividing the bandwidth by 2 a fourth of the area is considered and (roughly) a fourth of the number of observations is used for the local test. Thus, we observe a decrease in power of the test for decreasing values of bandwidths which is illustrated in Table 3.

h_0	level	power	level (cal.)	power (cal.)
0.3	0.5	7.8	4.6	35.3
0.4	0.2	29.6	4.5	71.7
0.5	0.1	71.7	4.0	93.3
0.6	0.2	95.3	4.8	99.5

Table 3: *Dependence of the power of the test (4.3) for a mode at the point $x^0 = (0, 0)^\top$ on the bandwidth in the situation of Table 2 where the number of observations is fixed to $n = 1000$. Second and third column: test defined by (4.3); fourth and fifth column: test defined by (4.3), where the quantiles $\kappa_n^j(\alpha)$ are replaced by calibrated quantiles.*

We also investigate the influence of the scale parameter σ on the power of the test (4.3). To this end, we fix the bandwidth as $h_0 = 0.5$ and the number of observations as $n = 1000$ and vary the value of σ . The results are shown in Table 4 and we observe that an increase in the

value of σ decreases the power of the test. On the other hand the power of the tests is very stable for small values of σ .

σ	level	power	level (cal.)	power (cal.)
0.0 (direct setting)	0.4	77.7	4.7	94.1
0.075	0.1	71.7	4.0	93.3
0.15	0.2	71.1	3.6	92.8
0.3	0.4	62.3	3.8	87.2
1.0	0.3	31.4	4.5	59.4

Table 4: *Dependence of the power of the test (4.3) for a mode at the point $x^0 = (0, 0)^\top$ on the scale parameter in the situation considered in Table 2 where the number of observations is fixed to $n = 1000$. Second and third column: test defined by (4.3); fourth and fifth column: test defined by (4.3), where the quantiles $\kappa_n^j(\alpha)$ are replaced by calibrated quantiles.*

Next we investigate the influence of the shape of the modal region on the power of the test (4.3). To this end, we fix the values of $h_0 = 0.5$ and $\sigma = 0.075$ and use normal distributed random variables Z_i with mean zero and non-diagonal covariance matrices

$$\Sigma_1 = \begin{pmatrix} 0 & 0.5 \\ -1 & 1.5 \end{pmatrix} \text{ and } \Sigma_2 = \begin{pmatrix} -0.5 & 1 \\ -2 & 2.5 \end{pmatrix}. \quad (4.4)$$

The simulated rejection probabilities are presented in Table 5 and show that the absolute values of the eigenvalues of the covariance matrix have an influence on the power of the test. In the case of $\mathcal{N}(0, \Sigma_1)$ -distributed random variables Z_i (eigenvalues 0.5 and 1) the test performs better as for standard normal observations (with both eigenvalues equal to one). In the case of $\mathcal{N}(0, \Sigma_2)$ -distributed random variables Z_i (eigenvalues 0.5 and 1.5) the test performs slightly worse than in the first case but still better as for standard normal observations due to the eigenvalue with absolute value smaller than one. We note again the superiority of the calibrated test.

We also investigate the influence of a (slight) misspecification of the position of the candidate mode on the power of the test (4.3) in the situation considered in Table 2 with candidate mode $x^0 = (0.2, 0.2)^\top$. The results are presented in Table 6. We find that the slight misspecification of the position of the candidate mode affects the power of the method only slightly.

Finally we consider a bimodal density and conduct simultaneously local tests for modality based on the hypotheses (2.4) for the candidate modes $x^1 = (0, 0)^\top$ and $x^2 = (3, 0)^\top$. We conduct eight tests for the hypotheses (2.4) for a fixed bandwidth $h = h_0 = 0.5$ with $s^1 = s^5 = t^1 = (1, 0)^\top$, $s^2 = s^6 = t^2 = (0, 1)^\top$, $s^3 = s^7 = t^3 = (-1, 0)^\top$, $s^4 = s^8 = t^4 = (0, -1)^\top$ and $t^5 = (4, 0)^\top$, $t^6 = (3, 1)^\top$, $t^7 = (2, 0)^\top$, $t^8 = (3, -1)^\top$ and conclude that f has a local maximum in $x^1 = (0, 0)^\top$

n	Σ_1		Σ_2	
	power	power (cal.)	power	power (cal.)
500	78.5	94.7	72.6	92.6
1000	96.7	99.3	96.5	98.9
4000	100	100	100	100

Table 5: *Dependence of the power of the test (4.3) for a mode at the point $x^0 = (0, 0)^\top$ on the shape of the modal region. The random variables Z_i are centered normal distributed with covariance matrices Σ_1 and Σ_2 given in (4.4). Second and fourth column: test defined by (4.3); third and fifth column: test defined by (4.3), where the quantiles $\kappa_n^j(\alpha)$ are replaced by calibrated quantiles.*

$x^0 = (0.2, 0.2)^\top$		
n	power	power (cal.)
500	34.9	70.8
1000	70.1	89.3
4000	99.9	100

Table 6: *Influence of a misspecification of the mode on the power of the test (4.3) for a mode at the point $x^0 = (0.2, 0.2)^\top$. The random variables Z_i in model (1.1) are standard normal distributed and therefore the true mode is given by $(0, 0)^\top$. Second column: test defined by (4.3); third column: test defined by (4.3), where the quantiles $\kappa_n^j(\alpha)$ are replaced by calibrated quantiles.*

whenever all hypotheses

$$H_{0,decr}^{s^j,t^j,h_0}, \quad j = 1, \dots, 4,$$

are rejected, that is

$$T_{s^j,t^j,h_0}^n > \kappa_n^j(\alpha) \quad \text{for all } j = 1, \dots, 4 \quad (4.5)$$

and that f has a local maximum in $x^2 = (3, 0)^\top$ whenever all hypotheses

$$H_{0,decr}^{s^j,t^j,h_0}, \quad j = 5, \dots, 8,$$

are rejected, that is

$$T_{s^j,t^j,h_0}^n > \kappa_n^j(\alpha) \quad \text{for all } j = 5, \dots, 8, \quad (4.6)$$

where the quantile $\kappa_n^j(\alpha)$ is defined by (3.10). An illustration of the considered scales is provided in Figure 3. For the investigation of the approximation of the nominal level we consider a uniform distribution on the rectangle $[-2.5, 5.5] \times [-2.5, 2.5]$ for the density f . The scaling factor in the Laplace density is given by $\sigma = 0.075$. For power investigations we consider two bimodal densities given by a uniform mixture of a standard normal distribution and a $\mathcal{N}((3, 0)^\top, I)$

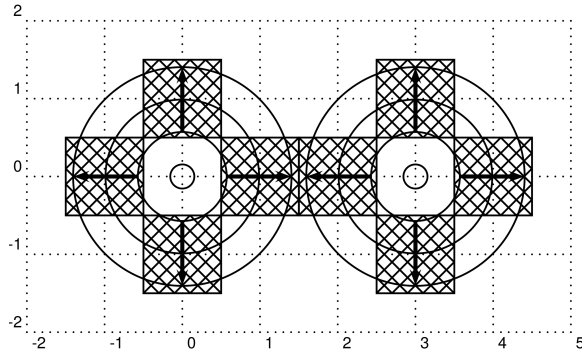

Figure 3: *Illustration of the eight local tests for monotonicity used to create the tests (4.5) and (4.6). The crosshatched squares display the support of the functions F_{s^j, t^j, h_0} , $j = 1, \dots, 8$, and the arrows the directional vectors s^j , $j = 1, \dots, 8$.*

distribution (symmetric) and a uniform mixture of a $\mathcal{N}((0,0)^\top, 1.2I)$ and a $\mathcal{N}((3.2, 0.1)^\top, 0.8I)$ distribution (asymmetric). The results for the calibrated version of the test are given in Table 7.

n	level	Symmetric		Asymmetric	
		power x^1	power x^2	power x^1	power x^2
500	5.3	34.6	33.0	23.6	48.5
1000	5.2	48.7	49.9	39.0	72.9
4000	4.2	84.4	81.7	76.1	97.1

Table 7: *Simulated level and power of the tests (4.5) and (4.6) for a mode at the points $x^1 = (0,0)^\top$ and $x^2 = (3,0)^\top$, where the quantiles $\kappa_n^j(\alpha)$ are replaced by calibrated quantiles. The random variables Z_i in model (1.1) are given by a uniform mixture of a standard normal distribution and a $\mathcal{N}((3,0)^\top, I)$ distribution (symmetric) and a uniform mixture of a $\mathcal{N}((0,0)^\top, 1.2I)$ and a $\mathcal{N}((3.2, 0.1)^\top, 0.8I)$ distribution (asymmetric).*

We observe that in the symmetric case the test detects both modes with (roughly) the same power, whereas in the asymmetric case the mode with smaller variance (even though there is a slight misspecification of its position) is detected more often.

A scatter plot of $n = 4000$ observations from the convolution of the asymmetric bimodal density and a bivariate Laplace distribution with scale parameter $\sigma = 0.5$ is given in Figure 4. Here, a look at the scatter plot does not give a hint on the number of modes of the distribution. However, the test (4.5), where the quantiles $\kappa_n^j(\alpha)$ are replaced by calibrated quantiles, is still able to detect a mode at $(0,0)^\top$ in 48.4 percent of the repetitions and the test (4.6) with calibrated quantiles detects a mode in $(3,0)^\top$ in 81.4 percent of the repetitions. The simulated

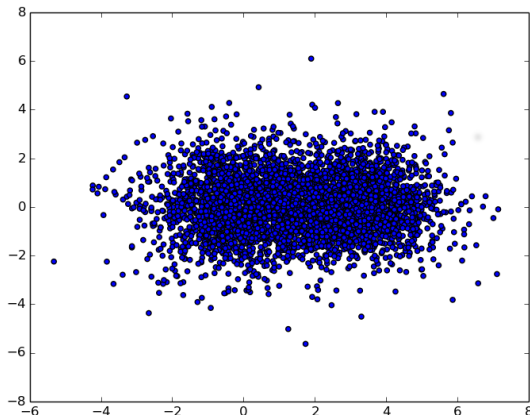

Figure 4: $n = 4000$ observations drawn from the convolution of a uniform mixture of a $\mathcal{N}((0.0)^\top, 1.2I)$ and a $\mathcal{N}((3.2, 0.1)^\top, 0.8I)$ distribution and a bivariate Laplace distribution with scale parameter $\sigma = 0.5$.

level for the calibrated quantiles is 4.1.

4.2 Inference about local monotonicity of a multivariate density

The multiscale approach introduced in Section 2 can be used to obtain a graphical representation of the monotonicity behavior of a (bivariate) density. We construct a global map indicating monotonicity properties of the density f by conducting the tests (3.9) for the hypotheses (2.2) for a fixed bandwidth of $h = 0.5$. The set of test locations \mathcal{T}_t is defined as the set of vertices of an equidistant grid in the square $[-1, 2]^2$ with width 1 and the set of test directions is given by $\mathcal{T}_s = \{s^1 = -s^3 = \sqrt{2}^{-1}(1, 1)^\top, s^2 = -s^4 = \sqrt{2}^{-1}(-1, 1)^\top\}$. The tests (3.9) are conducted for every triple

$$(s, t, h_0) \in \mathcal{T}_s \times \mathcal{T}_t \times \{h_0\}.$$

The scaling factor for the Laplace density in the convolution model (1.1) is given by $\sigma = 0.075$. We consider the tri-modal density with differently shaped modal regions displayed in Figure 5.

Figure 1 in Section 2 provides the graphical representation of the monotonicity behavior of the density f . Here, each arrow at a location t in direction s displays a rejection of a hypothesis (2.2). The map indicates the existence of modes close to the points $(-0.5, -0.5)^\top$, $(1.5, -0.5)^\top$ and $(0.5, 1.5)^\top$.

Acknowledgements. This work has been supported in part by the Collaborative Research Center “Statistical modeling of nonlinear dynamic processes” (SFB 823, Project A1, C1, C4) of

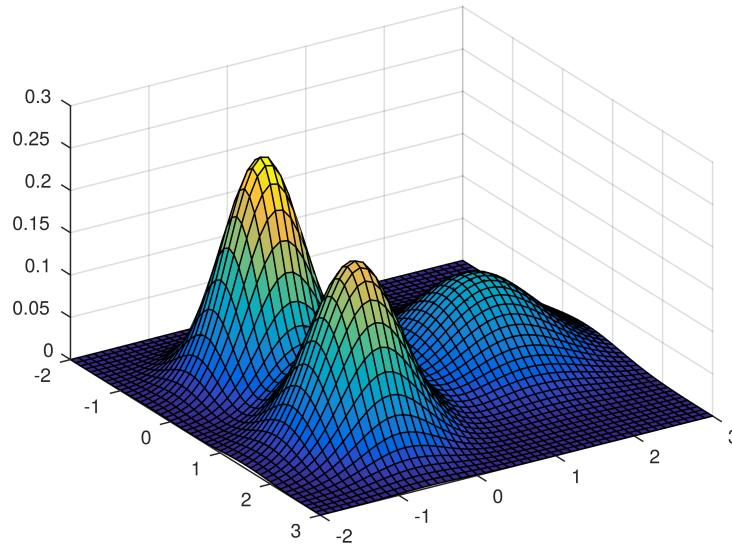

Figure 5: The density of a (uniform) mixture of a $\mathcal{N}((-0.4, -0.57)^\top, 0.2I)$, $\mathcal{N}((1.5, -0.6)^\top, 0.25I)$ and $\mathcal{N}((0.45, 1.6)^\top, 0.5I)$ distribution.

the German Research Foundation (DFG). The authors would like to thank Martina Stein, who typed parts of this manuscript with considerable technical expertise.

References

- Adler, R. and Taylor, J. (2007). *Random Fields and Geometry*. Springer Monographs in Mathematics. Springer New York.
- Adorf, H. M. (1995). Hubble space telescope image restoration in its fourth year. *Inverse Problems*, 11(4):639.
- Balabdaoui, F., Bissantz, K., Bissantz, N., and Holzmann, H. (2010). Demonstrating single and multiple currents through the *e. coli*-SecYEG-pore: testing for the number of modes of noisy observations. *J. Amer. Statist. Assoc.*, 105(489):136–146.
- Bertero, M., Boccacci, P., Desiderà, G., and Vicidomini, G. (2009). Image deblurring with Poisson data: from cells to galaxies. *Inverse Problems*, 25(12):123006, 26.
- Bissantz, N., Dümbgen, L., Holzmann, H., and Munk, A. (2007). Non-parametric confidence bands in deconvolution density estimation. *J. Roy. Statist. Soc. Ser. B*, 69(3):483–506.
- Bissantz, N. and Holzmann, H. (2008). Statistical inference for inverse problems. *Inverse Problems*, 24(3):034009, 17.
- Butucea, C. and Matias, C. (2005). Minimax estimation of the noise level and of the deconvolution density in a semiparametric convolution model. *Bernoulli*, 11(2):309–340.

- Carroll, R. J. and Hall, P. (1988). Optimal rates of convergence for deconvolving a density. *J. Amer. Statist. Assoc.*, 83(404):1184–1186.
- Cavaliere, L. (2000). Efficient estimation of a density in a problem of tomography. *Ann. Statist.*, 28(2):630–647.
- Chernozhukov, V., Chetverikov, D., and Kato, K. (2016). Central limit theorems and bootstrap in high dimensions. *Preprint, arXiv:1412.3661*.
- Comte, F. and Lacour, C. (2013). Anisotropic adaptive kernel deconvolution. *Ann. Inst. Henri Poincaré Probab. Stat.*, 49(2):569–609.
- Diggle, P. J. and Hall, P. (1993). A Fourier approach to nonparametric deconvolution of a density estimate. *J. Roy. Statist. Soc. Ser. B*, 55(2):523–531.
- Dümbgen, L. and Spokoiny, V. G. (2001). Multiscale testing of qualitative hypotheses. *Ann. Statist.*, 29(1):124–152.
- Eckle, K., Bissantz, N., Dette, H., Proksch, K., and Einecke, S. (2016). Multiscale inference for a multivariate density with applications to x-ray astronomy. *Preprint, arXiv:1412.3661*.
- Fan, J. (1991). On the optimal rates of convergence for nonparametric deconvolution problems. *Ann. Statist.*, 19(3):1257–1272.
- Giné, E. and Guillou, A. (2002). Rates of strong uniform consistency for multivariate kernel density estimators. *Ann. Inst. H. Poincaré Probab. Statist.*, 38(6):907–921. En l’honneur de J. Bretagnolle, D. Dacunha-Castelle, I. Ibragimov.
- Grund, B. and Hall, P. (1995). On the minimisation of L^p error in mode estimation. *Annals of Statistics*, 23:2264–2284.
- Holzmann, H., Bissantz, N., and Munk, A. (2007). Density testing in a contaminated sample. *J. Multivariate Anal.*, 98(1):57–75.
- Khoshnevisan, D. (2002). *Multiparameter Processes: An Introduction to Random Fields*. Monographs in Mathematics. Springer.
- Kotz, S., Kozubowski, T. J., and Podgórski, K. (2001). *Symmetric Multivariate Laplace Distribution*. Birkhäuser Boston, Boston, MA.
- Meister, A. (2009). On testing for local monotonicity in deconvolution problems. *Statist. Probab. Lett.*, 79(3):312–319.
- Pensky, M. and Vidakovic, B. (1999). Adaptive wavelet estimator for nonparametric density deconvolution. *Ann. Statist.*, 27(6):2033–2053.
- Romano, J. (1988). On weak convergence and optimality of kernel density estimates of the mode. *Annals of Statistics*, 16:629–647.
- Sarkar, A., Pati, D., Mallick, B. K., and Carroll, R. J. (2015). Bayesian semiparametric multivariate density deconvolution. *Preprint, arXiv:1404.6462*.
- Schmidt-Hieber, J., Munk, A., and Dümbgen, L. (2013). Multiscale methods for shape constraints in deconvolution: confidence statements for qualitative features. *Ann. Statist.*, 41(3):1299–1328.
- van Es, B., Jongbloed, G., and van Zuijlen, M. (1998). Isotonic inverse estimators for nonparametric deconvolution. *Ann. Statist.*, 26(6):2395–2406.

5 Proof of Theorem 3.1

We split the proof of Theorem 3.1 in three parts. The first part is dedicated to several auxiliary results involving the deconvolution kernel $F_{s,t,h}$. In the second part of the proof we show the approximation (3.7). Finally we conclude by proving the boundedness of the limit distribution in the third part.

Throughout this section the symbols \lesssim and \gtrsim mean less or equal and greater or equal, respectively, up to a multiplicative constant independent of n and (s, t, h) , and the symbol $|a_{s,t,h}| \asymp |b_{s,t,h}|$ means that $|a_{s,t,h}/b_{s,t,h}|$ is bounded from above and below by positive constants.

5.1 Auxiliary results

We begin with some basic transformations of the deconvolution kernel $F_{s,t,h}$. Recall that

$$F_{s,t,h}(\cdot) = \mathcal{F}^{-1}\left(\frac{\mathcal{F}(\partial_s \phi_{t,h})}{\mathcal{F}(f_\varepsilon)}\right)(\cdot) = h^{-d-1} \mathcal{F}^{-1}\left(\frac{\int_{\mathbb{R}^d} e^{-iy \cdot x} (\partial_s \phi)((x-t)/h) dx}{\mathcal{F}(f_\varepsilon)(y)}\right)(\cdot)$$

by definition of the kernel $\phi_{t,h}$ and the Fourier transform. A substitution in the inner integral shows that

$$F_{s,t,h}(\cdot) = h^{-1} \mathcal{F}^{-1}\left(\frac{e^{-iy \cdot t} \mathcal{F}(\partial_s \phi)(hy)}{\mathcal{F}(f_\varepsilon)(y)}\right)(\cdot). \quad (5.1)$$

By the definition of the inverse Fourier transform and a substitution in the outer integral, we obtain

$$F_{s,t,h}(x) = \frac{h^{-1}}{(2\pi)^d} \int_{\mathbb{R}^d} e^{ix \cdot y} \frac{e^{-iy \cdot t} \mathcal{F}(\partial_s \phi)(hy)}{\mathcal{F}(f_\varepsilon)(y)} dy = \frac{h^{-d-1}}{(2\pi)^d} \int_{\mathbb{R}^d} e^{iy \cdot \frac{x-t}{h}} \frac{\mathcal{F}(\partial_s \phi)(y)}{\mathcal{F}(f_\varepsilon)(y/h)} dy. \quad (5.2)$$

Furthermore, as $\partial_s \phi = \sum_{k=1}^d s_k \partial_{e^k} \phi$, where e^k , $k = 1, \dots, d$, denotes the k th unit vector of \mathbb{R}^d , we have

$$\mathcal{F}(\partial_s \phi)(y) = \sum_{k=1}^d s_k i y_k \mathcal{F}(\phi)(y),$$

where i denotes the imaginary unit. The following lemma presents some immediate consequences of the Assumptions 2 and 3 made in Section 3.

Lemma 5.1. *Let $l \in \{1, \dots, d\}$, $m \geq 2$ and $\tilde{m} = \lceil (d+1)/m \rceil$. It holds*

- (i) $S_s = \int_{\mathbb{R}^d} (1 + \|y\|^2)^{r/2} |\mathcal{F}(\partial_s \phi)(y)| dy < \infty$ uniformly with respect to s ;
- (ii) $\int_{\mathbb{R}^d} \left| \frac{\partial^{\tilde{m}}}{\partial y_l^{\tilde{m}}} \left(\frac{\mathcal{F}(\partial_s \phi)(y)}{\mathcal{F}(f_\varepsilon)(y/h)} \right) \right| dy \lesssim h^{-r}$.

Proof of Lemma 5.1:

(i): An application of Cauchy-Schwartz's inequality yields for any $\delta > 0$

$$\begin{aligned} S_s &= \int_{\mathbb{R}^d} (1 + \|y\|^2)^{r/2+(d+\delta)/4} (1 + \|y\|^2)^{-(d+\delta)/4} |\mathcal{F}(\partial_s \phi)(y)| \, dy \\ &\leq \left(\int_{\mathbb{R}^d} (1 + \|y\|^2)^{r+(d+\delta)/2} |\mathcal{F}(\partial_s \phi)(y)|^2 \, dy \right)^{1/2} \|(1 + \|y\|^2)^{-(d+\delta)/4}\|_{L^2(\mathbb{R}^d)}. \end{aligned}$$

By Assumption 3, there exists a constant $\delta > 0$ such that the latter integral is bounded uniformly with respect to s . Hence, the assertion follows from the integrability of the function $(1 + \|y\|^2)^{-(d+\delta)/2}$.

(ii): By Leibniz's rule we have

$$\left| \frac{\partial^{\tilde{m}}}{\partial y_l^{\tilde{m}}} \left(\frac{\mathcal{F}(\partial_s \phi)(y)}{\mathcal{F}(f_\varepsilon)(y/h)} \right) \right| \lesssim \sum_{k=0}^{\tilde{m}} \left| \frac{\partial^{\tilde{m}-k}}{\partial y_l^{\tilde{m}-k}} \mathcal{F}(\partial_s \phi)(y) \frac{\partial^k}{\partial y_l^k} \frac{1}{\mathcal{F}(f_\varepsilon)(y/h)} \right|.$$

Moreover, from Lemma 7.2 it follows that

$$\left| \frac{\partial^k}{\partial y_l^k} \frac{1}{\mathcal{F}(f_\varepsilon)(y/h)} \right| \lesssim \sum_{(m_1, \dots, m_k) \in \mathcal{M}_k} \frac{1}{|\mathcal{F}(f_\varepsilon)(y/h)|^{m_1 + \dots + m_k + 1}} h^{-k} \prod_{j=1}^k \left| \left(\frac{\partial^j}{\partial y_l^j} \mathcal{F}(f_\varepsilon) \right)(y/h) \right|^{m_j},$$

where \mathcal{M}_k is the set of all k -tuples of non-negative integers satisfying $\sum_{j=1}^k j m_j = k$. Assumption 2 in Section 3 yields the estimates

$$\left| \frac{\partial^j}{\partial y_l^j} \mathcal{F}(f_\varepsilon)(y) \right| \lesssim (1 + \|y\|^2)^{-(r+j)/2} \quad \text{and} \quad \frac{1}{|\mathcal{F}(f_\varepsilon)(y)|} \lesssim (1 + \|y\|^2)^{r/2}.$$

Thus, as $\sum_{j=1}^k j m_j = k$ for some $(m_1, \dots, m_k) \in \mathcal{M}_k$, we find

$$\begin{aligned} \left| \frac{\partial^k}{\partial y_l^k} \frac{1}{\mathcal{F}(f_\varepsilon)(y/h)} \right| &\lesssim h^{-k} \sum_{(m_1, \dots, m_k) \in \mathcal{M}_k} (1 + \|\frac{y}{h}\|^2)^{(m_1 + \dots + m_k + 1)r/2} \prod_{j=1}^k (1 + \|\frac{y}{h}\|^2)^{-m_j(r+j)/2} \\ &\lesssim h^{-k} \sum_{(m_1, \dots, m_k) \in \mathcal{M}_k} (1 + \|\frac{y}{h}\|^2)^{(m_1 + \dots + m_k + 1)r/2} (1 + \|\frac{y}{h}\|^2)^{-(m_1 + \dots + m_k)r/2 - k/2} \\ &\lesssim h^{-k} (1 + \|\frac{y}{h}\|^2)^{(r-k)/2}. \end{aligned}$$

Hence,

$$\left| \frac{\partial^{\tilde{m}}}{\partial y_l^{\tilde{m}}} \left(\frac{\mathcal{F}(\partial_s \phi)(y)}{\mathcal{F}(f_\varepsilon)(y/h)} \right) \right| \lesssim \sum_{k=0}^{\tilde{m}} h^{-k} \left| \frac{\partial^{\tilde{m}-k}}{\partial y_l^{\tilde{m}-k}} \mathcal{F}(\partial_s \phi)(y) \right| (1 + \|\frac{y}{h}\|^2)^{(r-k)/2}.$$

In the case $r \geq k$, the claim is now a direct consequence of the estimate

$$h^{-k} (1 + \|\frac{y}{h}\|^2)^{(r-k)/2} \lesssim h^{-r} (1 + \|y\|^2)^{(r-k)/2},$$

similar arguments as given in proof of (i) and Assumption 3.

If $r < k$ we divide the integration area into the ball $B_1(0)$ and its complement. For the integral

$$h^{-k} \int_{B_1(0)^c} \left| \frac{\partial^{\tilde{m}-k}}{\partial y_l^{\tilde{m}-k}} \mathcal{F}(\partial_s \phi)(y) \right| (1 + \|\frac{y}{h}\|^2)^{(r-k)/2} dy$$

we have $h^{-k} (1 + \|\frac{y}{h}\|^2)^{(r-k)/2} \lesssim h^{-r}$. Therefore, we can bound the integral over the complement of the unit ball by the integral over \mathbb{R}^d and proceed similarly to the first case. It remains to consider the integral over the ball $B_1(0)$. To this end, notice that

$$h^{-k} (1 + \|\frac{y}{h}\|^2)^{(r-k)/2} \leq h^{-r} \|y\|^{r-k}.$$

Hence, by the boundedness of $\frac{\partial^{\tilde{m}-k}}{\partial y_l^{\tilde{m}-k}} \mathcal{F}(\partial_s \phi)$ (which follows from the compactness of the support of ϕ) it remains to show that the integral

$$\int_{B_1(0)} \|y\|^{r-k} dy \lesssim \int_0^1 \rho^{d-1+r-k} d\rho$$

is bounded, where we used a polar coordinate transform to obtain the inequality. As $k \leq \lceil (d+1)/2 \rceil$ and $r > 0$, the integral on the right hand side is obviously finite. \square

Part (i) of the following lemma shows that the constants V_1, \dots, V_p defined in (3.5) are uniformly bounded from above and below.

Lemma 5.2. *It holds*

$$(i) \|F_{s,t,h}\|_{L^2(\mathbb{R}^d)} \asymp h^{-d/2-r-1};$$

$$(ii) \|F_{s,t,h}\|_{L^2(\mathbb{R}^d)} \|x-t\| \lesssim h^{-d/2-r};$$

$$(iii) \|F_{s,t,h} F_{s',t',h'}\|_{L^1(\mathbb{R}^d)} \lesssim (hh')^{-d/2-r-1};$$

$$(iv) \|F_{s,t,h} F_{s',t',h'}\|_{L^1(\mathbb{R}^d)} \|x-t\| \|x-t'\| \lesssim (hh')^{-d/2-r}.$$

Proof of Lemma 5.2:

(i): Using Plancherel's theorem and the representation (5.1), we obtain

$$\|F_{s,t,h}\|_{L^2(\mathbb{R}^d)}^2 \asymp h^{-2} \left\| \frac{e^{-iy \cdot t} \mathcal{F}(\partial_s \phi)(h \cdot)}{\mathcal{F}(f_\varepsilon)(\cdot)} \right\|_{L^2(\mathbb{R}^d)}^2 = h^{-2} \int_{\mathbb{R}^d} \left| \frac{\mathcal{F}(\partial_s \phi)(hy)}{\mathcal{F}(f_\varepsilon)(y)} \right|^2 dy. \quad (5.3)$$

It now follows from Assumption 2 and a substitution that

$$\|F_{s,t,h}\|_{L^2(\mathbb{R}^d)}^2 \lesssim h^{-d-2r-2} \int_{\mathbb{R}^d} (1 + \|y\|^2)^r |\mathcal{F}(\partial_s \phi)(y)|^2 dy,$$

and the latter integral is bounded by Assumption 3 which concludes the proof of the upper bound.

For the lower bound we find from (5.3) and Assumption 2 that

$$\begin{aligned} \|F_{s,t,h}\|_{L^2(\mathbb{R}^d)}^2 &\gtrsim h^{-2} \int_{\mathbb{R}^d} (1 + \|y\|^2)^r |\mathcal{F}(\partial_s \phi)(hy)|^2 dy \\ &\gtrsim h^{-d-2} \int_{\mathbb{R}^d} (1 + \|\frac{y}{h}\|^2)^r |\mathcal{F}(\partial_s \phi)(y)|^2 dy \gtrsim h^{-d-2r-2} \int_{B_a(0)^C} |\mathcal{F}(\partial_s \phi)(y)|^2 dy \end{aligned}$$

for any constant $a > 0$. Moreover,

$$\int_{B_a(0)^C} |\mathcal{F}(\partial_s \phi)(y)|^2 dy = \int_{\mathbb{R}^d} |\mathcal{F}(\partial_s \phi)(y)|^2 dy - \int_{B_a(0)} |\mathcal{F}(\partial_s \phi)(y)|^2 dy \gtrsim \|\partial_s \phi\|_{L^2(\mathbb{R}^d)}^2$$

for a sufficiently small radius a by the integrability of $|\mathcal{F}(\partial_s \phi)|^2$ (Assumption 3) and Plancherel's theorem. Furthermore, the mapping $s \mapsto \|\partial_s \phi\|_{L^2(\mathbb{R}^d)}$ is continuous such that by Assumption 3 $\|\partial_s \phi\|_{L^2(\mathbb{R}^d)} \geq c > 0$ for a constant c that does not depend on s .

(ii): The representation (5.2) and a substitution in the integral for the variable x show

$$\|F_{s,t,h}\|_{L^2(\mathbb{R}^d)}^2 = \frac{h^{-d}}{(2\pi)^{2d}} \int_{\mathbb{R}^d} \|x\|^2 \left| \int_{\mathbb{R}^d} e^{iy \cdot x} \frac{\mathcal{F}(\partial_s \phi)(y)}{\mathcal{F}(f_\varepsilon)(y/h)} dy \right|^2 dx.$$

As $\|x\|^2 = x_1^2 + \dots + x_d^2$, the differentiation rule for Fourier transforms yields

$$\begin{aligned} \|F_{s,t,h}\|_{L^2(\mathbb{R}^d)}^2 &= \frac{h^{-d}}{(2\pi)^{2d}} \sum_{k=1}^d \int_{\mathbb{R}^d} \left| \int_{\mathbb{R}^d} e^{iy \cdot x} \frac{\partial}{\partial y_k} \left(\frac{\mathcal{F}(\partial_s \phi)(y)}{\mathcal{F}(f_\varepsilon)(y/h)} \right) dy \right|^2 dx \\ &= h^{-d} \sum_{k=1}^d \left\| \mathcal{F}^{-1} \left(\frac{\partial}{\partial y_k} \left(\frac{\mathcal{F}(\partial_s \phi)(y)}{\mathcal{F}(f_\varepsilon)(y/h)} \right) \right) \right\|_{L^2(\mathbb{R}^d)}^2 \\ &\asymp h^{-d} \sum_{k=1}^d \left\| \frac{\partial}{\partial y_k} \left(\frac{\mathcal{F}(\partial_s \phi)(y)}{\mathcal{F}(f_\varepsilon)(y/h)} \right) \right\|_{L^2(\mathbb{R}^d)}^2, \end{aligned}$$

where the last identity follows from Plancherel's theorem. We now proceed similarly as in the proof of Lemma 5.1 (ii) and note that

$$\frac{\partial}{\partial y_k} \frac{\mathcal{F}(\partial_s \phi)(y)}{\mathcal{F}(f_\varepsilon)(y/h)} = \frac{\partial}{\partial y_k} \mathcal{F}(\partial_s \phi)(y) \frac{1}{\mathcal{F}(f_\varepsilon)(y/h)} - \frac{\mathcal{F}(\partial_s \phi)(y)}{(\mathcal{F}(f_\varepsilon)(y/h))^2} \frac{\partial}{\partial y_k} (\mathcal{F}(f_\varepsilon)(y/h)).$$

An application of the Assumptions 2 and 3 shows

$$\left\| \frac{\partial}{\partial y_k} \mathcal{F}(\partial_s \phi)(y) \frac{1}{\mathcal{F}(f_\varepsilon)(y/h)} \right\|_{L^2(\mathbb{R}^d)}^2 \lesssim h^{-2r} \int_{\mathbb{R}^d} \left| \frac{\partial}{\partial y_k} \mathcal{F}(\partial_s \phi)(y) \right|^2 (1 + \|y\|^2)^r dy \lesssim h^{-2r}.$$

Moreover, by Assumption 2, we have

$$\left\| \frac{\mathcal{F}(\partial_s \phi)(y)}{(\mathcal{F}(f_\varepsilon)(y/h))^2} \frac{\partial}{\partial y_k} (\overline{\mathcal{F}(f_\varepsilon)}(y/h)) \right\|_{L^2(\mathbb{R}^d)}^2 \lesssim h^{-2} \int_{\mathbb{R}^d} |\mathcal{F}(\partial_s \phi)(y)|^2 (1 + \|\frac{y}{h}\|^2)^{r-1} dy.$$

This concludes the proof for $r \geq 1$. For $r < 1$ we split up the area of integration into the ball $B_1(0)$ and its complement and find the required result for the integration over the complement using similar arguments as in the proof of Lemma 5.1 (ii). For the integral over the unit ball we also follow the line of arguments presented in the proof of Lemma 5.1 (ii) which yields the required result provided that the integral on the right hand side of the inequality

$$\int_{B_1(0)} \|y\|^{2r-2} dy \lesssim \int_0^1 \rho^{d-1+2r-2} d\rho$$

exists. This is the case for all $r > 0$ if $d \geq 2$ and all $r > \frac{1}{2}$ in the case $d = 1$.

(iii) and (iv): These are direct consequences of Hölder's inequality and (i) resp. (ii). □

The following Lemma will be used in the second part of the proof of Theorem 3.1.

Lemma 5.3. *For $1 \leq j, k \leq p$ and $m \geq 2$ we have for the function $F_j = F_{s^j, t^j, h_j}$ defined in (3.2)*

$$(i) |F_j(x)| \lesssim h_j^{-d-r-1} \text{ for all } x \in \mathbb{R}^d;$$

$$(ii) \mathbb{E}(|F_j(Y_1)|^m) \lesssim h_j^{-(m-1)d-mr-m}.$$

Proof of Lemma 5.3:

(i): Using the representation (5.2) and Assumption 2 it follows that

$$|F_j(x)| \lesssim h_j^{-d-1} \int_{\mathbb{R}^d} \left| \frac{\mathcal{F}(\partial_{s^j} \phi)(y)}{\mathcal{F}(f_\varepsilon)(y/h_j)} \right| dy \lesssim h_j^{-d-r-1} \int_{\mathbb{R}^d} (1 + \|y\|^2)^{r/2} |\mathcal{F}(\partial_{s^j} \phi)(y)| dy = h_j^{-d-r-1} S_{s^j}.$$

The claim follows from the uniform boundedness of S_{s^j} shown in Lemma 5.1 (i).

(ii): Using the representation (5.2), the boundedness of the density g and a substitution we get

$$\begin{aligned} \int_{\mathbb{R}^d} |F_j(x)|^m g(x) dx &\lesssim h_j^{-md-m} \int_{\mathbb{R}^d} \left| \int_{\mathbb{R}^d} e^{iy \cdot \frac{x-t^j}{h_j}} \frac{\mathcal{F}(\partial_{s^j} \phi)(y)}{\mathcal{F}(f_\varepsilon)(y/h_j)} dy \right|^m dx \\ &= h_j^{-(m-1)d-m} \int_{\mathbb{R}^d} \left| \int_{\mathbb{R}^d} e^{ix \cdot y} \frac{\mathcal{F}(\partial_{s^j} \phi)(y)}{\mathcal{F}(f_\varepsilon)(y/h_j)} dy \right|^m dx. \end{aligned}$$

The proof will be completed showing the estimate

$$\int_{\mathbb{R}^d} \left| \int_{\mathbb{R}^d} e^{ix \cdot y} \frac{\mathcal{F}(\partial_{sj}\phi)(y)}{\mathcal{F}(f_\varepsilon)(y/h_j)} dy \right|^m dx \lesssim h_j^{-mr}.$$

For this purpose we decompose the domain of integration for the variable x in two parts: the cube $[-\delta, \delta]^d$ for some $\delta > 0$ and its complement. For the integral with respect to the cube we use the upper bound $\int_{\mathbb{R}^d} \left| \frac{\mathcal{F}(\partial_{sj}\phi)(y)}{\mathcal{F}(f_\varepsilon)(y/h_j)} \right| dy \lesssim h_j^{-r}$ provided in the proof of (i) which yields the required result.

For the integral with respect to $([-\delta, \delta]^d)^C$ note that

$$\int_{([--\delta, \delta]^d)^C} \left| \int_{\mathbb{R}^d} e^{ix \cdot y} \frac{\mathcal{F}(\partial_{sj}\phi)(y)}{\mathcal{F}(f_\varepsilon)(y/h_j)} dy \right|^m dx \leq \sum_{k=1}^d \sum_{l=1}^d \int_{A_{k,l}} \left| \int_{\mathbb{R}^d} e^{ix \cdot y} \frac{\mathcal{F}(\partial_{sj}\phi)(y)}{\mathcal{F}(f_\varepsilon)(y/h_j)} dy \right|^m dx,$$

where the sets $A_{k,l}$ are defined by

$$A_{k,l} = \{x \in \mathbb{R}^d \mid |x_k| > \delta, |x_l| \geq |x_{l'}| \text{ for all } l' \neq l\}.$$

Now $\tilde{m} = \lceil (d+1)/m \rceil$ fold integration by parts yields

$$\left| \int_{\mathbb{R}^d} e^{ix \cdot y} \frac{\mathcal{F}(\partial_{sj}\phi)(y)}{\mathcal{F}(f_\varepsilon)(y/h_j)} dy \right|^m = \frac{1}{|x_l|^{m\tilde{m}}} \left| \int_{\mathbb{R}^d} e^{ix \cdot y} \frac{\partial^{\tilde{m}}}{\partial y_l^{\tilde{m}}} \left(\frac{\mathcal{F}(\partial_{sj}\phi)(y)}{\mathcal{F}(f_\varepsilon)(y/h_j)} \right) dy \right|^m,$$

provided that $\frac{\partial^{\tilde{m}}}{\partial y_l^{\tilde{m}}} \left(\frac{\mathcal{F}(\partial_{sj}\phi)(y)}{\mathcal{F}(f_\varepsilon)(y/h_j)} \right) \in L^1(\mathbb{R}^d)$, which holds by Lemma 5.1 (ii). A further application of Lemma 5.1 (ii) shows that

$$\int_{A_{k,l}} \left| \int_{\mathbb{R}^d} e^{ix \cdot y} \frac{\mathcal{F}(\partial_{sj}\phi)(y)}{\mathcal{F}(f_\varepsilon)(y/h_j)} dy \right|^m dx \lesssim h_j^{-mr} \int_{[-\delta, \delta]^d} \frac{|x_l|^{d-1}}{|x_l|^{d+1}} dx_l,$$

as $|x_{l'}| \leq |x_l|$ for all $l' \neq l$ and $|x_l| > \delta$ in $A_{k,l}$. □

5.2 Proof of the approximation (3.7)

For the consideration of the absolute values we introduce the set

$$\mathcal{T}'_n := \mathcal{T}_n \cup \{(-s, t, h) \mid (s, t, h) \in \mathcal{T}_n\} =: \{(s^j, t^j, h_j) \mid j = 1, \dots, 2p\}$$

and denote by \mathcal{A}' the set of all hyperrectangles in \mathbb{R}^{2p} of the form

$$A = \{w \in \mathbb{R}^{2p} \mid a_j \leq w_j \leq b_j \text{ for all } 1 \leq j \leq 2p\}$$

for some $-\infty \leq a_j \leq b_j \leq \infty$ ($1 \leq j \leq 2p$).

We will show below in Section 5.2.1 that the random vectors $X_i = (X_{i,1}, \dots, X_{i,2p})^\top \in \mathbb{R}^{2p}$, $i = 1, \dots, n$, with

$$X_{i,j} = h_j^{d/2+r+1} (F_j(Y_i) - \mathbb{E}(F_j(Y_1))) \quad (i = 1, \dots, n, j = 1, \dots, 2p)$$

fulfill

$$\sup_{A \in \mathcal{A}'} \left| \mathbb{P} \left(\frac{1}{\sqrt{n}} \sum_{i=1}^n X_i \in A \right) - \mathbb{P} \left(\frac{1}{\sqrt{n}} \sum_{i=1}^n Y'_i \in A \right) \right| \lesssim \left(\frac{h_{\min}^{-d} \log^7(n)}{n} \right)^{1/6} + \left(\frac{h_{\min}^{-d} \log^3(n)}{n^{1-2/q}} \right)^{1/3} \quad (5.4)$$

for any $q > 0$, where Y'_1, \dots, Y'_n are independent random vectors, $Y'_i = (Y'_{i,1}, \dots, Y'_{i,2p})^\top \sim \mathcal{N}(0, \mathbb{E}(X_i X_i^\top))$, $i = 1, \dots, n$. Note that we have

$$\frac{1}{\sqrt{n}} \sum_{i=1}^n Y'_i \sim N(0, \mathbb{E}(X_1 X_1^\top)),$$

where

$$\mathbb{E}(X_1 X_1^\top) = \left((h_j h_k)^{d/2+r+1} (\mathbb{E}(F_j(Y_1) F_k(Y_1)) - \mathbb{E}(F_j(Y_1)) \mathbb{E}(F_k(Y_1))) \right)_{1 \leq j, k \leq 2p},$$

as the random variables X_1, \dots, X_n are i.i.d. and Y'_1, \dots, Y'_n are independent.

Introduce a Gaussian process $(\tilde{B}(\Phi))_{\Phi \in L^\infty(\mathbb{R}^d)}$ indexed by $L^\infty(\mathbb{R}^d)$ as a process whose mean and covariance functions are 0 and

$$\int_{\mathbb{R}^d} \Phi_1(x) \Phi_2(x) g(x) dx - \int_{\mathbb{R}^d} \Phi_1(x) g(x) dx \int_{\mathbb{R}^d} \Phi_2(x) g(x) dx, \quad (5.5)$$

respectively. Hence, there exists a version of $\tilde{B}(\Phi)$ such that

$$\frac{1}{\sqrt{n}} \sum_{i=1}^n Y'_i = (h_1^{d/2+r+1} \tilde{B}(F_1), \dots, h_{2p}^{d/2+r+1} \tilde{B}(F_{2p}))^\top.$$

To derive an alternative representation of the process \tilde{B} recall the definition of the isonormal process $(B(\Phi))_{\Phi \in L^2(\mathbb{R}^d)}$ as a Gaussian process whose mean and covariance functions are 0 and $\int_{\mathbb{R}^d} \Phi_1(x) \Phi_2(x) dx$, respectively (see, e.g. Khoshnevisan (2002), Section 5.1). In particular, note that $(B(\mathbb{1}_A))_{A \in \mathcal{B}(\mathbb{R}^d)}$ defines white noise, where $\mathcal{B}(\mathbb{R}^d)$ denotes the Borel- σ -field on \mathbb{R}^d . Throughout this paper, we will use the notation $B(\Phi) = \int_{\mathbb{R}^d} \Phi(x) dB_x$.

There exists a version of the isonormal process such that $\tilde{B}(\Phi) = B(\Phi \sqrt{g}) - \int_{\mathbb{R}^d} \Phi(x) g(x) dx B(\sqrt{g})$ for $\Phi \in L^\infty(\mathbb{R}^d)$ (one proves easily that $(B(\Phi \sqrt{g}) - \int_{\mathbb{R}^d} \Phi(x) g(x) dx B(\sqrt{g}))_{\Phi \in L^\infty(\mathbb{R}^d)}$ defines a Gaussian process with the covariance kernel (5.5)). Thus,

$$\max_{1 \leq j \leq 2p} |\tilde{B}(F_j) - B(F_j \sqrt{g})| = \max_{1 \leq j \leq 2p} \left| \int_{\mathbb{R}^d} F_j(x) g(x) dx B(\sqrt{g}) \right|.$$

From (2.5) we have

$$\left| \int_{\mathbb{R}^d} F_j(x)g(x)dx \right| = |\mathbb{E}[F_j(Y_1)]| = \left| \int_{\mathbb{R}^d} \partial_s f(x)\phi_{t,h}(x)dx \right| = O(1) \quad (5.6)$$

uniformly with respect to s, t, h (by assumption). Furthermore,

$$B(\sqrt{g}) \sim N\left(0, \int_{\mathbb{R}^d} g(x) dx\right) \sim N(0, 1),$$

which implies that

$$\mathbb{E}\left(\max_{1 \leq j \leq 2p} h_j^{d/2+r+1} |\tilde{B}(F_j) - B(F_j\sqrt{g})|\right) \lesssim h_{\max}^{d/2+r+1}.$$

An application of Markov's inequality finally proves

$$\max_{1 \leq j \leq 2p} h_j^{d/2+r+1} |\tilde{B}(F_j) - B(F_j\sqrt{g})| = O_{\mathbb{P}}(|\log(h_{\max})|^{1/2} h_{\max}^{d/2+r+1}). \quad (5.7)$$

Here, we have investigated convergence in probability w.r.t. the sup-norm. However, standard arguments show that this implies the convergence which is investigated in Theorem 3.1.

In a second step we find that the normalization with $c_j := (\sqrt{g(t^j)}V_j)^{-1}$, $j = 1, \dots, 2p$, has no influence on the convergence as translation and multiplication preserve the interval structure. More precisely, for any set $A = [a_1, b_1] \times \dots \times [a_{2p}, b_{2p}] \in \mathcal{A}'$ we have

$$\begin{aligned} & \left\{ (c_j h_j^{d/2+r+1} B(F_j\sqrt{g}))_{j=1}^{2p} \in A \right\} \\ &= \left\{ (h_j^{d/2+r+1} B(F_j\sqrt{g}))_{j=1}^{2p} \in [c_1^{-1}a_1, c_1^{-1}b_1] \times \dots \times [c_{2p}^{-1}a_{2p}, c_{2p}^{-1}b_{2p}] \right\}, \end{aligned} \quad (5.8)$$

where $[c_1^{-1}a_1, c_1^{-1}b_1] \times \dots \times [c_{2p}^{-1}a_{2p}, c_{2p}^{-1}b_{2p}]$ still defines an element of the set \mathcal{A}' . A similar result holds for the normalization of the test statistic.

In a third step we show in Section 5.2.2 that the normalization with the density estimator yields to a distribution-free limit process. We firstly assume that the density g is known and prove

$$\max_{1 \leq j \leq 2p} \left| h_j^{d/2+r+1} \frac{B(F_j\sqrt{g})}{\sqrt{g(t^j)}V_j} - h_j^{d/2+r+1} \frac{B(F_j)}{V_j} \right| = O_{\mathbb{P}}(\sqrt{h_{\max} \log(n) \log \log(n)}) = o_{\mathbb{P}}(1). \quad (5.9)$$

Hence, by the consideration of the symmetric set \mathcal{T}'_n it follows from (5.4), (5.7) and (5.9) that

$$\sup_{A \in \mathcal{A}} \left| \mathbb{P}\left(\left(\frac{1}{\sqrt{ng(t^j)}V_j} \left| \sum_{i=1}^n X_{i,j} \right|\right)_{j=1}^p \in A\right) - \mathbb{P}\left(\left(h_j^{d/2+r+1} \frac{|B(F_j)|}{V_j}\right)_{j=1}^p \in A\right) \right| = o(1), \quad (5.10)$$

as for any real valued random variable X and any $a \in \mathbb{R}$ it holds

$$\{|X| \in (-\infty, a]\} = \{X \in (-\infty, a]\} \cap \{-X \in (-\infty, a]\}.$$

Next we insert the bandwidth normalization terms. To this end, we introduce the notation

$$w(h) = \frac{\sqrt{\log(eh^{-d})}}{\log \log(e^e h^{-d})}, \quad \tilde{w}(h) = \sqrt{2 \log(h^{-d})}$$

and write $w_j = w(h_j)$, $\tilde{w}_j = \tilde{w}(h_j)$. Similar arguments as in (5.8) show that the insertion of the bandwidth correction terms has no influence on the convergence. Thus recalling the definition of $\tilde{X}_j = w_j(h_j^{d/2+r+1} \frac{|B(F_j)|}{V_j} - \tilde{w}_j)$ in (3.6) we obtain from (5.10)

$$\sup_{A \in \mathcal{A}} \left| \mathbb{P} \left(\left(w_j \left(\frac{1}{\sqrt{ng(t_j)V_j}} \left| \sum_{i=1}^n X_{i,j} \right| - \tilde{w}_j \right) \right)_{j=1}^p \in A \right) - \mathbb{P}(\tilde{X} \in A) \right| = o(1), \quad (5.11)$$

and it remains to replace the true density by its estimator. For this purpose we show that

$$\max_{1 \leq j \leq p} \left| w_j \left(\frac{1}{\sqrt{ng(t_j)V_j}} \left| \sum_{i=1}^n X_{i,j} \right| - \tilde{w}_j \right) - \tilde{X}_j^{(1)} \right| = O_{\mathbb{P}} \left(\frac{1}{\log \log(n)} \right),$$

where $\tilde{X}_j^{(1)}$ is defined in (3.3). Note that

$$w_j \frac{1}{\sqrt{nV_j}} \left| \sum_{i=1}^n X_{i,j} \right| \left| \frac{1}{\sqrt{g(t^j)}} - \frac{1}{\sqrt{\hat{g}_n(t^j)}} \right| \lesssim w_j \frac{1}{\sqrt{ng(t^j)V_j}} \left| \sum_{i=1}^n X_{i,j} \right| \|g - \hat{g}_n\|_{\infty}$$

almost surely by the boundedness from below of g (and therefore of \hat{g}_n almost surely). A null addition of the term \tilde{w}_j shows that the latter is equal to

$$w_j \left(\frac{1}{\sqrt{ng(t_j)V_j}} \left| \sum_{i=1}^n X_{i,j} \right| - \tilde{w}_j \right) \|g - \hat{g}_n\|_{\infty} + w_j \tilde{w}_j \|g - \hat{g}_n\|_{\infty}.$$

The claim follows now from the convergence of $(w_j \left(\frac{1}{\sqrt{ng(t_j)V_j}} \left| \sum_{i=1}^n X_{i,j} \right| - \tilde{w}_j \right))_{j=1}^p$ proven in (5.11) and the a.s. boundedness of the maximum of the limiting process proven in Section 5.3 below. Note that we used the fact that

$$h \mapsto \frac{\log(eh^{-d})}{\log \log(e^e h^{-d})}$$

is decreasing in a neighborhood of 0 (cf. Schmidt-Hieber et al. (2013), Lemma B.11).

5.2.1 Proof of (5.4)

The proof of (5.4) mainly relies on Proposition 2.1 in Chernozhukov et al. (2016). The result is stated as follows.

Theorem 5.4. Let X_1, \dots, X_n be independent random vectors in \mathbb{R}^{2p} with $\mathbb{E}(X_{i,j}) = 0$ and $\mathbb{E}(X_{i,j}^2) < \infty$ for $i = 1, \dots, n$, $j = 1, \dots, 2p$. Moreover, let Y'_1, \dots, Y'_n be independent random vectors in \mathbb{R}^{2p} with $Y'_i \sim N(0, \mathbb{E}(X_i X_i^\top))$, $i = 1, \dots, n$. Let $b, q > 0$ be some constants and let $B_n \geq 1$ be a sequence of constants, possibly growing to infinity as $n \rightarrow \infty$. Assume that the following conditions are satisfied:

- (i) $n^{-1} \sum_{i=1}^n \mathbb{E}(X_{i,j}^2) \geq b$ for all $1 \leq j \leq 2p$;
- (ii) $n^{-1} \sum_{i=1}^n \mathbb{E}(|X_{i,j}|^{2+k}) \leq B_n^k$ for all $1 \leq j \leq 2p$ and $k = 1, 2$;
- (iii) $\mathbb{E}((\max_{1 \leq j \leq 2p} |X_{i,j}|/B_n)^q) \leq 2$ for all $i = 1, \dots, n$.

Then,

$$\sup_{A \in \mathcal{A}'} \left| \mathbb{P}\left(\frac{1}{\sqrt{n}} \sum_{i=1}^n X_i \in A\right) - \mathbb{P}\left(\frac{1}{\sqrt{n}} \sum_{i=1}^n Y'_i \in A\right) \right| \leq C(D_n^{(1)} + D_{n,q}^{(2)}),$$

where the sequences $D_n^{(1)}$ and $D_{n,q}^{(2)}$ are given by

$$D_n^{(1)} = \left(\frac{B_n^2 \log^7(2pn)}{n}\right)^{1/6}, \quad D_{n,q}^{(2)} = \left(\frac{B_n^2 \log^3(2pn)}{n^{1-2/q}}\right)^{1/3}$$

and the constant C depends only on b and q .

For an application of Theorem 5.4 we have to verify the condition (i) and to find an appropriate sequence B_n for conditions (ii) and (iii). For a proof of condition (i) notice that

$$\mathbb{E}(X_{1,j}^2) = h_j^{d+2r+2} \mathbb{E}((F_j(Y_1))^2) - h_j^{d+2r+2} (\mathbb{E}(F_j(Y_1)))^2 \gtrsim h_j^{d+2r+2} (\mathbb{E}((F_j(Y_1))^2) - 1),$$

where we used (5.6) in the inequality. Moreover, as the density of g is bounded from below (Assumption 1) we have

$$\begin{aligned} h_j^{d+2r+2} \mathbb{E}((F_j(Y_1))^2) &= h_j^{d+2r+2} \int_{\mathbb{R}^d} (F_j(x))^2 g(x) dx \\ &\gtrsim h_j^{d+2r+2} \int_{[-\delta, 1+\delta]^d} (F_j(x))^2 dx \\ &= h_j^{d+2r+2} \int_{\mathbb{R}^d} (F_j(x))^2 dx - h_j^{d+2r+2} \int_{([- \delta, 1+\delta]^d)^c} (F_j(x))^2 dx. \end{aligned}$$

In Lemma 5.2 (i) we have proven that $\|F_j\|_{L^2(\mathbb{R}^d)}^2 \gtrsim h_j^{-d-2r-2}$, and using the representation (5.2) we obtain

$$\int_{([- \delta, 1+\delta]^d)^c} (F_j(x))^2 dx \lesssim h_j^{-2d-2} \int_{([- \delta, 1+\delta]^d)^c} \left| \int_{\mathbb{R}^d} e^{iy \cdot \frac{x-tj}{h_j}} \frac{\mathcal{F}(\partial_{sj} \phi)(y)}{\mathcal{F}(f_\varepsilon)(y/h_j)} dy \right|^2 dx.$$

Moreover, $[-t_1^j - \delta, -t_1^j + 1 + \delta] \times \dots \times [-t_d^j - \delta, -t_d^j + 1 + \delta] \supseteq [-\delta, \delta]^d$ and a substitution show

$$\int_{([-\delta, 1 + \delta]^d)^c} \left| \int_{\mathbb{R}^d} e^{iy \cdot \frac{x - t^j}{h_j}} \frac{\mathcal{F}(\partial_{s^j} \phi)(y)}{\mathcal{F}(f_\varepsilon)(y/h_j)} dy \right|^2 dx \leq \int_{([-\delta, \delta]^d)^c} \left| \int_{\mathbb{R}^d} e^{iy \cdot \frac{x}{h_j}} \frac{\mathcal{F}(\partial_{s^j} \phi)(y)}{\mathcal{F}(f_\varepsilon)(y/h_j)} dy \right|^2 dx.$$

We now follow the line of arguments presented in the proof of Lemma 5.3 (ii) for $m = 2$ and note that by conducting integration by parts we get an additional factor h_j^{d+1} . Hence,

$$\int_{([-\delta, 1 + \delta]^d)^c} (F_j(x))^2 dx \lesssim h_j^{-d-2r-1}. \quad (5.12)$$

This concludes the proof of condition (i) as $\mathbb{E}(X_{1,j}^2) \gtrsim 1 - h_j - h_j^{d+2r+2}$ and $h_j \leq h_{\max} \rightarrow 0$ for $n \rightarrow \infty$.

For a proof of condition (ii) note that by part (ii) of Lemma 5.3 it follows that

$$h_j^{(2+k)(d/2+r+1)} \mathbb{E}(|F_j(Y_1)|^{2+k}) \lesssim h_j^{-kd/2} \text{ for } k = 1, 2,$$

and therefore B_n can be chosen proportional to $h_{\min}^{-d/2}$.

An application of Lemma 5.3 (i) yields

$$|X_{i,j}| \lesssim h_j^{-d/2}$$

and therefore condition (iii) of Theorem 5.4 holds for any $q > 0$ for the choice of $B_n = ch_{\min}^{-d/2}$, provided that the constant is chosen sufficiently large.

Hence, Theorem 5.4 proves (recall that $p \leq n^K$)

$$\sup_{A \in \mathcal{A}'} \left| \mathbb{P}\left(\frac{1}{\sqrt{n}} \sum_{i=1}^n X_i \in A\right) - \mathbb{P}\left(\frac{1}{\sqrt{n}} \sum_{i=1}^n Y_i' \in A\right) \right| \lesssim \left(\frac{h_{\min}^{-d} \log^7(n)}{n}\right)^{1/6} + \left(\frac{h_{\min}^{-d} \log^3(n)}{n^{1-2/q}}\right)^{1/3}$$

for any $q > 0$, which proves (5.4).

5.2.2 Proof of (5.9)

Define

$$R_j := h_j^{d/2+r+1} \int_{\mathbb{R}^d} F_j(x) (\sqrt{g(x)} - \sqrt{g(t^j)}) dB_x, \quad (5.13)$$

then the assertion follows from the statement

$$\max_{1 \leq j \leq 2p} |R_j| = O_{\mathbb{P}}\left(\sqrt{h_{\max} \log(n) \log \log(n)}\right).$$

Here, we used the fact that the constants V_1, \dots, V_{2p} are bounded uniformly from below (cf. Lemma 5.2). For this purpose, we will make use of a Slepian-type result. Note that for all $\delta > 0$

$$\begin{aligned} \mathbb{E}(R_j^2) &= h_j^{d+2r+2} \int_{[-\delta, 1+\delta]^d} (F_j(x)(\sqrt{g(x)} - \sqrt{g(t^j)}))^2 dx \\ &\quad + h_j^{d+2r+2} \int_{([- \delta, 1+\delta]^d)^c} (F_j(x)(\sqrt{g(x)} - \sqrt{g(t^j)}))^2 dx. \end{aligned} \quad (5.14)$$

For the first integral on the right hand side of (5.14) we use the Lipschitz continuity of g (Assumption 1) and find

$$h_j^{d+2r+2} \int_{[-\delta, 1+\delta]^d} (F_j(x)(\sqrt{g(x)} - \sqrt{g(t^j)}))^2 dx \lesssim h_j^{d+2r+2} \int_{[-\delta, 1+\delta]^d} \left(F_j(x) \|x - t^j\| \frac{1}{2\sqrt{\xi}} \right)^2 dx$$

for some ξ satisfying $|\xi - g(t^j)| \leq |g(x) - g(t^j)|$. If $\delta > 0$ is sufficiently small, then g is bounded from below on $[-\delta, 1+\delta]^d$ (see the remark following Assumption 1), and Lemma 5.2 (ii) shows that an upper bound of this term (up to some constant) is given by

$$h_j^{d+2r+2} \int_{\mathbb{R}^d} (F_j(x))^2 \|x - t^j\|^2 dx \lesssim h_{\max}^2.$$

The second integral on the right hand side of (5.14) is bounded by h_{\max} which follows from (5.12) and the boundedness of g (Assumption 1). Summarizing, we obtain

$$\mathbb{E}(R_j^2) \lesssim h_{\max}.$$

Moreover, we can show by similar calculations as presented above and an application of Lemma 5.2 (iv) that

$$|\mathbb{E}(R_j R_k)| = (h_j h_k)^{d/2+r+1} \left| \int_{\mathbb{R}^d} F_j(x)(\sqrt{g(x)} - \sqrt{g(t^j)}) F_k(x)(\sqrt{g(x)} - \sqrt{g(t^k)}) dx \right| \lesssim h_{\max}.$$

Introducing the random variables

$$\tilde{R}_j := h_j^{d/2+r+2} \int_{\mathbb{R}^d} F_j(x) dB_x,$$

we obtain from Lemma 5.2 (i) and (iii)

$$\mathbb{E}(\tilde{R}_j^2) \lesssim h_{\max}^2, \mathbb{E}(\tilde{R}_j \tilde{R}_k) \lesssim h_{\max}^2.$$

Hence,

$$\max_{1 \leq j, k \leq 2p} \left| \mathbb{E}((R_j - R_k)^2) - \mathbb{E}((\tilde{R}_j - \tilde{R}_k)^2) \right| \lesssim h_{\max},$$

and Theorem 2.2.5 in Adler and Taylor (2007) yields

$$\mathbb{E}\left(\max_{1 \leq j \leq 2p} R_j\right) = \mathbb{E}\left(\max_{1 \leq j \leq 2p} \tilde{R}_j\right) + O(\sqrt{h_{\max} \log(n)}).$$

Note that by the symmetry of the set \mathcal{T}'_n with respect to the direction we have $\mathbb{E}(\max_{1 \leq j \leq 2p} R_j) = \mathbb{E}(\max_{1 \leq j \leq 2p} |R_j|)$ and $\mathbb{E}(\max_{1 \leq j \leq 2p} \tilde{R}_j) = \mathbb{E}(\max_{1 \leq j \leq 2p} |\tilde{R}_j|)$, and we can consider expectations of positive random variables here.

For an upper bound of $\mathbb{E}(\max_{1 \leq j \leq 2p} \tilde{R}_j)$ we use the a.s. asymptotic boundedness of

$$\max_{1 \leq j \leq 2p} \frac{\sqrt{\log(eh_j^{-d})}}{\log \log(e^e h_j^{-d})} \left(h_j^{-1} \frac{\tilde{R}_j}{V_j} - \sqrt{2 \log(h_j^{-d})} \right)$$

shown in Section 5.3 below, which implies

$$\mathbb{E}\left(\max_{1 \leq j \leq 2p} \tilde{R}_j\right) = O\left(\sqrt{\log(n)} h_{\max}\right)$$

and therefore $\mathbb{E}(\max_{1 \leq j \leq 2p} R_j) = O(\sqrt{h_{\max} \log(n)})$. This proves (5.9) by an application of Markov's inequality.

5.3 Boundedness of the approximating statistic

In order to prove that the approximating statistic $\max_{1 \leq j \leq p} \tilde{X}_j$ considered in Theorem 3.1 is almost surely bounded uniformly with respect to $n \in \mathbb{N}$ we note that for all $p \in \mathbb{N}$

$$\max_{1 \leq j \leq p} \tilde{X}_j \leq B,$$

where the random variable B is defined by

$$B := \sup_{(s,t,h) \in S^{d-1} \times [0,1]^d \times (0,1]} \frac{\sqrt{\log(eh^{-d})}}{\log \log(e^e h^{-d})} \left(h^{d/2+r+1} \frac{\left| \int_{\mathbb{R}^d} F_{s,t,h}(x) dB_x \right|}{V_{s,t,h}} - \sqrt{2 \log(h^{-d})} \right),$$

where the constant $V_{s,t,h} = h^{d/2+r+1} \|F_{s,t,h}\|_{L^2(\mathbb{R}^d)}$. B does not depend on n and we show below that B is almost surely bounded. We will make use of the following result (Theorem 6.1 and Remark 1, Dümbgen and Spokoiny (2001)).

Theorem 5.5. *Let X be a stochastic process on a pseudometric space (\mathcal{T}, ρ) with continuous sample paths. Suppose that the following three conditions are satisfied.*

(i) *There is a function $\sigma : \mathcal{T} \rightarrow (0, 1]$ and a constant $K \geq 1$ such that*

$$\mathbb{P}(X(a) > \sigma(a)\eta) \leq K \exp(-\eta^2/2) \quad \text{for all } \eta > 0 \text{ and } a \in \mathcal{T}.$$

Moreover,

$$\sigma(b)^2 \leq \sigma(a)^2 + \rho(a, b)^2 \quad \text{for all } a, b \in \mathcal{T}.$$

(ii) For some constants $L, M \geq 1$,

$$\mathbb{P}(|X(a) - X(b)| > \rho(a, b)\eta) \leq L \exp(-\eta^2/M) \quad \text{for all } \eta > 0 \text{ and } a, b \in \mathcal{T}.$$

(iii) For some constants $A, B, V > 0$,

$$N((\delta u)^{1/2}, \{a \in \mathcal{T} : \sigma(a)^2 \leq \delta\}) \leq Au^{-B}\delta^{-V} \quad \text{for all } u, \delta \in (0, 1],$$

where $N(\varepsilon, \mathcal{T}')$ denotes the packing number of the set $\mathcal{T}' \subseteq \mathcal{T}$.

Then, the random variable

$$\sup_{a \in \mathcal{T}} \left(\frac{|X(a)|/\sigma(a) - (2 \log(1/\sigma(a)^2))^{1/2}}{(\log(e/\sigma(a)^2))^{-1/2} \log \log(e/\sigma(a)^2)} \right)$$

is finite almost surely.

For the application of Theorem 5.5 we introduce the pseudometric space (\mathcal{T}, ρ) , where $\mathcal{T} = S^{d-1} \times [0, 1]^d \times (0, 1]$ and

$$\rho((s^1, t^1, h_1), (s^2, t^2, h_2)) = (\|s^1 - s^2\|_1^2 + \|t^1 - t^2\| + |h_1^d - h_2^d|)^{1/2}$$

for $(s^1, t^1, h_1), (s^2, t^2, h_2) \in \mathcal{T}$. Moreover, for $(s, t, h) \in \mathcal{T}$ define $\sigma(s, t, h) = h^{d/2}$,

$$X(s, t, h) = \sigma(s, t, h) \frac{h^{d/2+r+1}}{V_{s,t,h}} \int_{\mathbb{R}^d} F_{s,t,h}(x) dB_x = \frac{h^{d+r+1}}{V_{s,t,h}} \int_{\mathbb{R}^d} F_{s,t,h}(x) dB_x.$$

In the following, we prove that the process X fulfills the conditions of Theorem 5.5.

(i): We have by definition of σ and ρ that

$$\sigma(b)^2 \leq \sigma(a)^2 + \rho(a, b)^2 \quad \text{for all } a, b \in \mathcal{T}.$$

Furthermore, it holds

$$\mathbb{P}(X(s, t, h) > \sigma(h)\eta) \leq \exp(-\eta^2/2)$$

as $X(s, t, h)/\sigma(h)$ corresponds in distribution to a normal distributed random variable with mean zero and variance one by definition of $V_{s,t,h}$.

(ii): By definition, $X(s^1, t^1, h_1) - X(s^2, t^2, h_2)$ corresponds in distribution to a normal distributed random variable with mean zero and variance

$$\left\| \frac{h_1^{d+r+1}}{V_{s^1, t^1, h_1}} F_{s^1, t^1, h_1} - \frac{h_2^{d+r+1}}{V_{s^2, t^2, h_2}} F_{s^2, t^2, h_2} \right\|_{L^2(\mathbb{R}^d)}^2.$$

W.l.o.g. we assume in the following $h_1 \leq h_2$ and note that condition (ii) (with $L = 2$) follows from the inequality

$$\begin{aligned} \left\| \frac{h_1^{d+r+1}}{V_{s^1, t^1, h_1}} F_{s^1, t^1, h_1} - \frac{h_2^{d+r+1}}{V_{s^2, t^2, h_2}} F_{s^2, t^2, h_2} \right\|_{L^2(\mathbb{R}^d)} &\lesssim \left\| h_1^{d+r+1} F_{s^1, t^1, h_1} - h_2^{d+r+1} F_{s^2, t^2, h_2} \right\|_{L^2(\mathbb{R}^d)} \\ &\quad + h_1^{d/2} |V_{s^1, t^1, h_1} - V_{s^2, t^2, h_2}| \\ &\lesssim \rho((s^1, t^1, h_1), (s^2, t^2, h_2)) \end{aligned} \quad (5.15)$$

for $(s^1, t^1, h_1), (s^2, t^2, h_2) \in S^{d-1} \times [0, 1]^d \times (0, 1]$. In the first inequality we used the fact that V_{s^1, t^1, h_1} is uniformly bounded from below and $\|h_1^{d+r+1} F_{s^1, t^1, h_1}\|_{L^2(\mathbb{R}^d)} \lesssim h_1^{d/2}$ as shown in Lemma 5.2 (i).

In a proof of the second inequality in (5.15) we note that by application of the triangle inequality

$$\begin{aligned} h_1^{d/2} |V_{s^1, t^1, h_1} - V_{s^2, t^2, h_2}| &= h_1^{d/2} \left| \|h_1^{d/2+r+1} F_{s^1, t^1, h_1}\|_{L^2(\mathbb{R}^d)} - \|h_2^{d/2+r+1} F_{s^2, t^2, h_2}\|_{L^2(\mathbb{R}^d)} \right| \\ &\leq h_1^{d/2} \|h_1^{d/2+r+1} F_{s^1, t^1, h_1} - h_2^{d/2+r+1} F_{s^2, t^2, h_2}\|_{L^2(\mathbb{R}^d)} \\ &\leq h_1^{d+r+1} \|F_{s^1, t^1, h_1} - F_{s^2, t^2, h_2}\|_{L^2(\mathbb{R}^d)} + \|F_{s^2, t^2, h_2}\|_{L^2(\mathbb{R}^d)} |h_1^{d+r+1} - h_1^{d/2} h_2^{d/2+r+1}|. \end{aligned}$$

In Lemma 5.2 (i) we have proven $\|F_{s^2, t^2, h_2}\|_{L^2(\mathbb{R}^d)} \lesssim h_2^{-d/2-r-1}$, which implies

$$\begin{aligned} h_1^{d/2} |V_{s^1, t^1, h_1} - V_{s^2, t^2, h_2}| &\lesssim h_1^{d+r+1} \|F_{s^1, t^1, h_1} - F_{s^2, t^2, h_2}\|_{L^2(\mathbb{R}^d)} + \left| \frac{h_1^{d+r+1}}{h_2^{d/2+r+1}} - h_1^{d/2} \right| \\ &\lesssim h_1^{d+r+1} \|F_{s^1, t^1, h_1} - F_{s^2, t^2, h_2}\|_{L^2(\mathbb{R}^d)} + |h_1^{d/2} - h_2^{d/2}|. \end{aligned} \quad (5.16)$$

Moreover, we find by another application of the inequality $\|F_{s^2, t^2, h_2}\|_{L^2(\mathbb{R}^d)} \lesssim h_2^{-d/2-r-1}$

$$\begin{aligned} \|h_1^{d+r+1} F_{s^1, t^1, h_1} - h_2^{d+r+1} F_{s^2, t^2, h_2}\|_{L^2(\mathbb{R}^d)} &\leq h_1^{d+r+1} \|F_{s^1, t^1, h_1} - F_{s^2, t^2, h_2}\|_{L^2(\mathbb{R}^d)} \\ &\quad + \|F_{s^2, t^2, h_2}\|_{L^2(\mathbb{R}^d)} |h_1^{d+r+1} - h_2^{d+r+1}| \\ &\lesssim h_1^{d+r+1} \|F_{s^1, t^1, h_1} - F_{s^2, t^2, h_2}\|_{L^2(\mathbb{R}^d)} + \left| \frac{h_1^{d+r+1}}{h_2^{d/2+r+1}} - h_2^{d/2} \right| \\ &\lesssim h_1^{d+r+1} \|F_{s^1, t^1, h_1} - F_{s^2, t^2, h_2}\|_{L^2(\mathbb{R}^d)} + |h_1^{d/2} - h_2^{d/2}|. \end{aligned} \quad (5.17)$$

Hence, observing (5.16) and (5.17) the inequality (5.15) follows from

$$h_1^{d+r+1} \|F_{s^1, t^1, h_1} - F_{s^2, t^2, h_2}\|_{L^2(\mathbb{R}^d)} + |h_1^{d/2} - h_2^{d/2}| \lesssim \rho((s^1, t^1, h_1), (s^2, t^2, h_2)). \quad (5.18)$$

For a proof of this inequality we use Plancherel's theorem which yields

$$\|F_{s^1, t^1, h_1} - F_{s^2, t^2, h_2}\|_{L^2(\mathbb{R}^d)}^2 \lesssim \int_{\mathbb{R}^d} (1 + \|y\|^2)^r \left| \mathcal{F} \left(h_1^{-d} \partial_{s^1} \phi \left(\frac{\cdot - t^1}{h_1} \right) - h_2^{-d} \partial_{s^2} \phi \left(\frac{\cdot - t^2}{h_2} \right) \right) (y) \right|^2 dy.$$

The integrand on the right hand side can be estimated as follows

$$\begin{aligned} \left| \mathcal{F} \left(h_1^{-d} \partial_{s^1} \phi \left(\frac{\cdot - t^1}{h_1} \right) - h_2^{-d} \partial_{s^2} \phi \left(\frac{\cdot - t^2}{h_2} \right) \right) (y) \right|^2 &\lesssim \left| \mathcal{F} \left(h_1^{-d} \partial_{s^1} \phi \left(\frac{\cdot - t^1}{h_1} \right) - h_1^{-d} \partial_{s^2} \phi \left(\frac{\cdot - t^1}{h_1} \right) \right) (y) \right|^2 \\ &\quad + \left| \mathcal{F} \left(h_1^{-d} \partial_{s^2} \phi \left(\frac{\cdot - t^1}{h_1} \right) - h_2^{-d} \partial_{s^2} \phi \left(\frac{\cdot - t^2}{h_2} \right) \right) (y) \right|^2, \end{aligned}$$

and we obtain

$$\begin{aligned}
& \|F_{s^1, t^1, h_1} - F_{s^2, t^2, h_2}\|_{L^2(\mathbb{R}^d)}^2 \\
& \lesssim \int_{\mathbb{R}^d} (1 + \|y\|^2)^r \left| \sum_{k=1}^d \left\{ s_k^1 \mathcal{F} \left(h_1^{-d} \partial_{e^k} \phi \left(\frac{\cdot - t^1}{h_1} \right) \right) (y) - s_k^2 \mathcal{F} \left(h_1^{-d} \partial_{e^k} \phi \left(\frac{\cdot - t_1}{h_1} \right) \right) (y) \right\} \right|^2 dy \\
& \quad + \int_{\mathbb{R}^d} (1 + \|y\|^2)^r \left| \mathcal{F} \left(h_1^{-d} \partial_{s^2} \phi \left(\frac{\cdot - t^1}{h_1} \right) - h_2^{-d} \partial_{s^2} \phi \left(\frac{\cdot - t^2}{h_2} \right) \right) (y) \right|^2 dy,
\end{aligned}$$

where e^k denotes the k th unit vector of \mathbb{R}^d ($k = 1, \dots, d$). By a substitution it follows that

$$\left| \mathcal{F} \left(h_1^{-d} \partial_{e^k} \phi \left(\frac{\cdot - t^1}{h_1} \right) \right) (y) \right| = h_1^{-1} \left| \mathcal{F} (\partial_{e^k} \phi) (h_1 y) \right|,$$

which gives

$$\begin{aligned}
& \|F_{s^1, t^1, h_1} - F_{s^2, t^2, h_2}\|_{L^2(\mathbb{R}^d)}^2 \\
& \lesssim h_1^{-d-2r-2} \|s^1 - s^2\|_1^2 \int_{\mathbb{R}^d} (1 + \|y\|^2)^r \left| \mathcal{F} (\partial_{e^k} \phi) (y) \right|^2 dy \\
& \quad + \int_{\mathbb{R}^d} (1 + \|y\|^2)^r \left| \mathcal{F} \left(h_1^{-d} \partial_{s^2} \phi \left(\frac{\cdot - t^1}{h_1} \right) \right) (y) - \mathcal{F} \left(h_1^{-d} \partial_{s^2} \phi \left(\frac{\cdot - t^2}{h_1} \right) \right) (y) \right|^2 dy \\
& \quad + \int_{\mathbb{R}^d} (1 + \|y\|^2)^r \left| \mathcal{F} \left(h_1^{-d} \partial_{s^2} \phi \left(\frac{\cdot - t^2}{h_1} \right) - h_2^{-d} \partial_{s^2} \phi \left(\frac{\cdot - t^2}{h_2} \right) \right) (y) \right|^2 dy.
\end{aligned} \tag{5.19}$$

Here, we used another substitution and the triangle inequality. For an upper bound for the first term on the right hand side of (5.19), note that by Assumption 3 $\int_{\mathbb{R}^d} (1 + \|y\|^2)^r \left| \mathcal{F} (\partial_{e^k} \phi) (y) \right|^2 dy$ is finite. Furthermore, a substitution within the Fourier transform shows that the second term of the right hand side of (5.19) is not greater than

$$\int_{\mathbb{R}^d} (1 + \|y\|^2)^r \left| e^{-iy \cdot t^1} - e^{-iy \cdot t^2} \right|^2 \left| \mathcal{F} \left(h_1^{-d} \partial_{s^2} \phi \left(\frac{\cdot}{h_1} \right) \right) (y) \right|^2 dy.$$

By an application of Euler's formula, $\cos(x) \geq 1 - x$ for all $x \geq 0$ and Cauchy-Schwartz's inequality, we find

$$\left| e^{-iy \cdot t^1} - e^{-iy \cdot t^2} \right|^2 = \left| 1 - e^{-iy \cdot (t^1 - t^2)} \right|^2 \lesssim (1 + \|y\|^2)^{1/2} \|t^1 - t^2\|.$$

Therefore, two substitutions and Assumption 3 show that the second term on the right hand side of (5.19) is bounded from above (up to some constant) by

$$\|t^1 - t^2\| \int_{\mathbb{R}^d} (1 + \|y\|^2)^{r+1/2} \left| \mathcal{F} \left(h_1^{-d} \partial_{s^2} \phi \left(\frac{\cdot}{h_1} \right) \right) (y) \right|^2 dy \lesssim h_1^{-d-2r-3} \|t^1 - t^2\|.$$

It remains to consider the third term on the right hand side of (5.19). Plancherel's theorem, the rule for the Fourier transform of a derivative and a substitution show that the third term

on the right hand side of (5.19) can be bounded by

$$\begin{aligned} & \sum_{|\alpha| \leq \lceil r+1 \rceil} \left\| \partial^\alpha \left(h_1^{-d} \phi\left(\frac{\cdot}{h_1}\right) - h_2^{-d} \phi\left(\frac{\cdot}{h_2}\right) \right) \right\|_{L^2(\mathbb{R}^d)}^2 \\ & \lesssim \sum_{|\alpha| \leq \lceil r+1 \rceil} \left\{ \frac{1}{h_1^{2d+2|\alpha|}} \left\| (\partial^\alpha \phi)\left(\frac{\cdot}{h_1}\right) - (\partial^\alpha \phi)\left(\frac{\cdot}{h_2}\right) \right\|_{L^2(\mathbb{R}^d)}^2 + \left\| (\partial^\alpha \phi)\left(\frac{\cdot}{h_2}\right) \right\|_{L^2(\mathbb{R}^d)}^2 \left| \frac{1}{h_1^{2d+2|\alpha|}} - \frac{1}{h_2^{2d+2|\alpha|}} \right| \right\}, \end{aligned} \quad (5.20)$$

where we have used Assumption 3. From the estimate $\|(\partial^\alpha \phi)\left(\frac{\cdot}{h_2}\right)\|_{L^2(\mathbb{R}^d)}^2 \lesssim h_2^d$ we obtain that the second term on the right hand side of (5.20) is bounded from above (up to some constant) by

$$h_2^d \left| \frac{1}{h_1^{2d+2|\alpha|}} - \frac{1}{h_2^{2d+2|\alpha|}} \right| \lesssim h_1^{-2d-2r-2} |h_1^d - h_2^d|$$

for all $|\alpha| \leq \lceil r+1 \rceil$. The first term on the right hand side of (5.20) can be bounded by Lemma 7.1 using Assumption 3, that is

$$\frac{1}{h_1^{2d+2|\alpha|}} \left\| (\partial^\alpha \phi)\left(\frac{\cdot}{h_1}\right) - (\partial^\alpha \phi)\left(\frac{\cdot}{h_2}\right) \right\|_{L^2(\mathbb{R}^d)}^2 \lesssim h_1^{-2d-2r-2} |h_1^d - h_2^d|$$

for all $|\alpha| \leq \lceil r+1 \rceil$, which proves that the right hand side of (5.20) is not greater (up to some constant) than $h_1^{-2d-2r-2} |h_1^d - h_2^d|$.

Hence,

$$\|F_{s^1, t^1, h_1} - F_{s^2, t^2, h_2}\|_{L^2(\mathbb{R}^d)}^2 \lesssim h_1^{-d-2r-2} \|s^1 - s^2\|_1^2 + h_1^{-d-2r-3} \|t^1 - t^2\| + h_1^{-2d-2r-2} |h_1^d - h_2^d|$$

proves (5.18) and concludes the proof of (ii).

(iii): Let $\tilde{N}(\varepsilon, \mathcal{T}') \equiv \tilde{N}(\varepsilon, \mathcal{T}', \rho)$ denote the covering number of the set $\mathcal{T}' \subseteq \mathcal{T}$ and note that covering and packing numbers are equivalent in the sense that

$$N(2\varepsilon, \mathcal{T}') \leq \tilde{N}(\varepsilon, \mathcal{T}') \leq N(\varepsilon, \mathcal{T}').$$

Hence, it suffices to find an upper bound for the cardinality of a well-chosen covering subset $\mathcal{T}' \subset S^{d-1} \times [0, 1]^d \times \{h \in (0, 1] : h^d \leq \delta\}$ that fulfills the following condition:

For any $(s^1, t^1, h_1) \in S^{d-1} \times [0, 1]^d \times \{h \in (0, 1] : h^d \leq \delta\}$ there exists $(s^2, t^2, h_2) \in \mathcal{T}'$ with $\rho^2((s^1, t^1, h_1), (s^2, t^2, h_2)) \leq \delta u$. It is easy to see that such a set is given by

$$\mathcal{T}' = \mathcal{T}'_1 \times \mathcal{T}'_2 \times \mathcal{T}'_3, \quad (5.21)$$

where \mathcal{T}'_1 is a covering subset of S^{d-1} with respect to $\sqrt{\varepsilon} = \frac{(\delta u)^{1/2}}{\sqrt{3}}$ and $\mathcal{T}'_2, \mathcal{T}'_3$ are covering subsets of $[0, 1]^d, \{h \in (0, 1] : h^d \leq \delta\}$, respectively, with respect to $\varepsilon = \frac{\delta u}{3}$. Here, the metrics under consideration are $(s^2, s^1) \mapsto \|s^2 - s^1\|_1, (t^2, t^1) \mapsto \|t^2 - t^1\|$ and $(h_2, h_1) \mapsto |h_2^d - h_1^d|$.

Again, we make use of the equivalence of packing and covering numbers and determine in the following upper bounds for the packing numbers of S^{d-1} and $[0, 1]^d$.

We begin with the determination of an upper bound for the packing number $N(\sqrt{\varepsilon}, S^{d-1})$ w.r.t. $\|\cdot\|_1$ for $\varepsilon > 0$. Note that by the equivalence of all norms in \mathbb{R}^d , the packing number $N(\sqrt{\varepsilon}, S^{d-1})$ w.r.t. $\|\cdot\|$ is of the same order in ε . We will therefore consider the latter.

Let \mathcal{T}'_1 be any subset of S^{d-1} such that $\|s^2 - s^1\| > \sqrt{\varepsilon}$ for all $s^2, s^1 \in \mathcal{T}'_1$, $s^2 \neq s^1$. By definition of \mathcal{T}'_1 , the open balls $B_{\frac{\sqrt{\varepsilon}}{2}}(s^2)$ and $B_{\frac{\sqrt{\varepsilon}}{2}}(s^1)$ are disjoint for all $s^2, s^1 \in \mathcal{T}'_1$, $s^2 \neq s^1$. Furthermore, every ball $B_{\frac{\sqrt{\varepsilon}}{2}}(s)$, $s \in \mathcal{T}'_1$, is contained in the annulus around the zero point with radii $1 + \frac{\sqrt{\varepsilon}}{2}$ and $1 - \frac{\sqrt{\varepsilon}}{2}$. Recall that the volume of this annulus is of the order $(1 + \frac{\sqrt{\varepsilon}}{2})^d - (1 - \frac{\sqrt{\varepsilon}}{2})^d$.

A simple volume argument gives

$$\#\mathcal{T}'_1 \lesssim \sqrt{\varepsilon}^{-d} \left((1 + \frac{\sqrt{\varepsilon}}{2})^d - (1 - \frac{\sqrt{\varepsilon}}{2})^d \right) \lesssim \varepsilon^{(-d+1)/2}.$$

It is a well-known fact that the packing number of $[0, 1]^d$ w.r.t. $\|\cdot\|$ fulfills $N(\varepsilon, [0, 1]^d) \lesssim \varepsilon^{-d}$. Hence, it remains to consider the covering number $\tilde{N}(\varepsilon, (0, \delta^{1/d}])$ w.r.t. the metric $(h_2, h_1) \mapsto |h_2^d - h_1^d|$. Observe that the distance between adjacent points in the set $\mathcal{T}'_3 := \{(j\varepsilon)^{1/d}, j = 1, \dots, \lfloor \frac{\delta}{\varepsilon} \rfloor\}$ is equal to ε . As a consequence, $\tilde{N}(\varepsilon, (0, \delta^{1/d}]) \lesssim \frac{\delta}{\varepsilon}$.

From (5.21) and the results presented above we deduce

$$N((\delta u)^{\frac{1}{2}}, \{a \in \mathcal{T} : \sigma(a)^2 \leq \delta\}) \lesssim u^{-\frac{3d-1}{2}} \delta^{-\frac{3d+1}{2}}.$$

It remains to prove the continuity of the sample paths of X . For this purpose, we will make use of Theorem 1.3.5 in Adler and Taylor (2007).

Define a further semimetric \tilde{d} on \mathcal{T} by

$$\tilde{d}((s^1, t^1, h_1), (s^2, t^2, h_2)) = (\mathbb{E}((X(s^1, t^1, h_1) - X(s^2, t^2, h_2))^2))^{1/2}$$

and the log-entropy $H(\varepsilon) = \log(\tilde{N}(\varepsilon, \mathcal{T}, \tilde{d}))$. Then, Theorem 1.3.5 in Adler and Taylor (2007) states that X has a.s. continuous sample paths with respect to the semimetric \tilde{d} if

$$\int_0^{\text{diam}(\mathcal{T})/2} H^{1/2}(\varepsilon) d\varepsilon < \infty,$$

where $\text{diam}(\mathcal{T}) = \sup_{(s^1, t^1, h_1), (s^2, t^2, h_2) \in \mathcal{T}} \tilde{d}((s^1, t^1, h_1), (s^2, t^2, h_2))$. However, by the definition of X , we have that

$$\begin{aligned} \tilde{d}((s^1, t^1, h_1), (s^2, t^2, h_2)) &= \|V_{s^1, t^1, h_1}^{-1} h_1^{d+r+1} F_{s^1, t^1, h_1} - V_{s^2, t^2, h_2}^{-1} h_2^{d+r+1} F_{s^2, t^2, h_2}\|_{L^2(\mathbb{R}^d)} \\ &\lesssim \rho((s^1, t^1, h_1), (s^2, t^2, h_2)), \end{aligned}$$

where the latter inequality has been proven in (ii). Hence, similar arguments as presented in (iii) show that $\tilde{N}(\varepsilon, \mathcal{T}, \tilde{d}) \lesssim \varepsilon^{-a}$ for some $a > 0$, which concludes the proof of the a.s. continuity of the sample paths of X w.r.t. \tilde{d} and implies the a.s. continuity of the sample paths of X w.r.t. ρ .

6 Proofs of Theorems 3.2 and 3.3

Proof of Theorem 3.2: Denote by q the probability of at least one false rejection among all tests (3.9) and (3.11). Using Theorem 3.1, we further deduce from (3.8)

$$\begin{aligned} q &= 1 - \mathbb{P}\left(n^{-1} \left| \sum_{i=1}^n F_j(Y_i) \right| \leq \kappa_n^j(\alpha) \text{ for all } j = 1, \dots, p\right) \\ &= 1 - \mathbb{P}\left(\tilde{X}_j^{(1)} \leq \kappa_n(\alpha) \text{ for all } j = 1, \dots, p\right) \\ &= 1 - \mathbb{P}\left(\tilde{X}_j \leq \kappa_n(\alpha) \text{ for all } j = 1, \dots, p\right) + o(1) \leq \alpha + o(1) \end{aligned}$$

for $n \rightarrow \infty$. □

Proof of Theorem 3.3: We begin deriving a criterion for the simultaneous rejection of the hypotheses (2.3) on a given set of scales. To this end, let $0 < (\alpha_n)_{n \in \mathbb{N}} < 1$ be an arbitrary null sequence and $J \subseteq \{1, \dots, p\}$ be the set of all indices where the inequality

$$\mathbb{E}(F_j(Y_1)) = - \int_{\mathbb{R}^d} \partial_{s^j} f(x) \phi_{t^j, h_j}(x) dx > 2\kappa_n^j(\alpha_n) \quad (6.1)$$

is satisfied. An application of Theorem 3.1 shows that the probability of simultaneous rejection of the Null Hypotheses for all tests in (3.11) indexed by J (where α is replaced by α_n) is asymptotically equal to one, i.e.

$$\tilde{q} := \mathbb{P}\left(n^{-1} \sum_{i=1}^n F_j(Y_i) > \kappa_n^j(\alpha_n) \text{ for all } j \in J\right) \geq 1 - \alpha_n + o(1) = 1 - o(1).$$

Indeed,

$$\begin{aligned} \tilde{q} &\geq \mathbb{P}\left(n^{-1} \sum_{i=1}^n F_j(Y_i) - \mathbb{E}(F_j(Y_1)) \geq -\kappa_n^j(\alpha_n) \text{ for all } j \in J\right) \\ &\geq \mathbb{P}\left(\left|n^{-1} \sum_{i=1}^n F_j(Y_i) - \mathbb{E}(F_j(Y_1))\right| \leq \kappa_n^j(\alpha_n) \text{ for all } j \in J\right) \\ &\geq 1 - \alpha_n + o(1) \end{aligned}$$

by similar arguments as presented in the proof of Theorem 3.2.

Now let $x^0 \in (0, 1)^d$ be a mode of f and $(s, t, h) \in \mathcal{T}_n^{x^0}$, i.e. $ch \geq \|x^0 - t\| \geq 2\sqrt{d}h$ for some $c > 2\sqrt{d}$ and $\text{angle}(x^0 - t, s) \rightarrow 0$ for $n \rightarrow \infty$. Following the line of arguments presented in the proof of Theorem 3.3 in Eckle et al. (2016), one can prove that, under the given assumptions, $\partial_s f(x) \lesssim -h$ for all $x \in \text{supp} \phi_{t, h}$. Hence,

$$- \int_{\mathbb{R}^d} \phi_{t, h}(x) \partial_s f(x) dx \gtrsim h.$$

As $\kappa_n(\alpha_n)$ is uniformly bounded by Theorem 3.1, we find that

$$\frac{h^{-d/2-r-1}}{\sqrt{n}} \left(\frac{\log \log(e^e h^{-d})}{\sqrt{\log(eh^{-d})}} \kappa_n(\alpha_n) + \sqrt{2 \log(h^{-d})} \right) \lesssim \frac{h^{-d/2-r-1}}{\sqrt{n}} \sqrt{\log(h^{-d})}.$$

For a proof of (6.1) it remains to find a condition on h such that

$$h^{d/2+r+2} \gtrsim \frac{1}{\sqrt{n}} \sqrt{\log(h^{-d})},$$

which holds for $h \geq C \log(n)^{1/(d+2r+4)} n^{-1/(d+2r+4)}$ for some $C > 0$ sufficiently large. \square

7 Two technical results

Lemma 7.1. *Let $\Phi : \mathbb{R}^d \rightarrow \mathbb{R}$ be continuously differentiable with compact support. Then,*

$$\left\| \Phi\left(\frac{\cdot}{h_1}\right) - \Phi\left(\frac{\cdot}{h_2}\right) \right\|_{L^2(\mathbb{R}^d)}^2 \lesssim |h_1^d - h_2^d|$$

for all $h_1, h_2 \in (0, 1]$.

Proof of Lemma 7.1: W.l.o.g. we assume in the following that $h_1 \leq h_2$ and obtain

$$\begin{aligned} & \int_{\mathbb{R}^d} \left(\Phi\left(\frac{x}{h_1}\right) - \Phi\left(\frac{x}{h_2}\right) \right)^2 dx \\ &= \int_{\mathbb{R}^d} \Phi^2\left(\frac{x}{h_1}\right) dx + \int_{\mathbb{R}^d} \Phi^2\left(\frac{x}{h_2}\right) dx - 2 \int_{\mathbb{R}^d} \Phi\left(\frac{x}{h_1}\right) \Phi\left(\frac{x}{h_2}\right) dx \\ &= h_1^d \int_{\mathbb{R}^d} \Phi^2(x) dx + h_2^d \int_{\mathbb{R}^d} \Phi^2(x) dx - 2h_1^d \int_{\mathbb{R}^d} \Phi(x) \Phi\left(\frac{h_1}{h_2}x\right) dx. \end{aligned} \quad (7.1)$$

Observe that

$$\Phi\left(\frac{h_1}{h_2}x\right) = \Phi(x) + \left(-1 + \frac{h_1}{h_2}\right)x \cdot \nabla \Phi(\xi)$$

for some ξ on the line that connects x and $\frac{h_1}{h_2}x$. Hence, the term in (7.1) is bounded by

$$\begin{aligned} & (h_2^d - h_1^d) \int_{\mathbb{R}^d} \Phi^2(x) dx + 2h_1^d \left|1 - \frac{h_1}{h_2}\right| \sup_{y \in \text{supp} \Phi} \|\nabla \Phi(y)\| \int_{\mathbb{R}^d} |\Phi(x)| \|x\| dx \\ & \lesssim (h_2^d - h_1^d) + h_1^d - \frac{h_1^{d+1}}{h_2} \lesssim h_2^d - h_1^d. \end{aligned}$$

\square

Lemma 7.2 (Faà di Brunos formula). *Let $k \in \mathbb{N}$ and assume that $h_1, h_2 : \mathbb{R} \rightarrow \mathbb{R}$ are sufficiently smooth functions. Then,*

$$\frac{d^k}{dx^k} h_1(h_2(x)) = \sum_{(m_1, \dots, m_k) \in \mathcal{M}_k} \frac{k!}{m_1! \dots m_k!} h_1^{(m_1 + \dots + m_k)}(h_2(x)) \prod_{j=1}^k \left(\frac{h_2^{(j)}(x)}{j!} \right)^{m_j} \quad (7.2)$$

for every $x \in \mathbb{R}$, where \mathcal{M}_k is the set of all k -tuples of non-negative integers satisfying $\sum_{j=1}^k j m_j = k$.